



ZBOX AND ZARGEN



G*GRASS®

ZBOX & ZARGEN DRAWER SYSTEMS

ZBox and Zargen steel drawer systems provide the flexibility to handle the most demanding design needs with quick construction and simple installation.







Versatile. Reliable. Proven.

ZBox and Zargen drawer systems offer versatility in application and deliver superior performance with a tried-and-tested technology.

Innovative functional solutions.

For years the Zargen metal drawer system has provided cabinet makers the quality, functionality, and versatility expected of Grass hardware. From residential and office furniture to commercial and institutional settings, the Zargen System consistently delivers superior performance. Offering five side heights and flexible railing systems, the Zargen drawer provides endless possibilities for the well-organized storage system.



The Grass ZBox offers all the same features of the Zargen system but with one new twist - the Zargen

drawer side is mounted to a Grass ball bearing slide to create a new full extension metal drawer. The combined strength of the ball bearing slides with the Zargen's steel construction offers a drawer solution that saves time and money with its quick drawer box construction and simple installation. The ZBox offers standard drawer and deep drawer heights, railing system, and Pendaflex filing systems to provide a wide range of possibilities for your cabinet construction.



ZBox & Zargen

Table of Content

	Description	Adjustment	Page
	ZBox Features and Benefits		6
	ZBox Technical Information		8
	ZBox 6423 <ul style="list-style-type: none"> • 213mm (8 3/8") Side Height • Integrated drawer slide and side • Full Extension 	<ul style="list-style-type: none"> • Height adjustment $\pm 2.0\text{mm}$ via cam • Side adjustment $\pm 1.5\text{mm}$ 	10
	ZBox 6223 <ul style="list-style-type: none"> • 149mm (5 7/8") Side Height • Integrated drawer slide and side • Full Extension 	<ul style="list-style-type: none"> • Height adjustment $\pm 2.0\text{mm}$ via cam • Side adjustment $\pm 1.5\text{mm}$ 	12
	ZBox 6023 <ul style="list-style-type: none"> • 85mm (3 3/8") Side Height • Integrated drawer slide and side • Full Extension 	<ul style="list-style-type: none"> • Height adjustment $\pm 2.0\text{mm}$ via cam • Side adjustment $\pm 1.5\text{mm}$ 	14
	Zargen Features and Benefits		16
	Zargen Technical Information		18
	Zargen 6436 <ul style="list-style-type: none"> • 213mm (8 3/8") Side Height • Integrated drawer slide and side 	<ul style="list-style-type: none"> • Height adjustment $\pm 2.0\text{mm}$ via cam • Side adjustment $\pm 1.5\text{mm}$ 	20
	Zargen 6236 <ul style="list-style-type: none"> • 149mm (5 7/8") Side Height • Integrated drawer slide and side 	<ul style="list-style-type: none"> • Height adjustment $\pm 2.0\text{mm}$ via cam • Side adjustment $\pm 1.5\text{mm}$ 	22
	Zargen 6136 <ul style="list-style-type: none"> • 117mm (4 5/8") Side Height • Integrated drawer slide and side 	<ul style="list-style-type: none"> • Height adjustment $\pm 2.0\text{mm}$ via cam • Side adjustment $\pm 1.5\text{mm}$ 	24
	Zargen 6036 <ul style="list-style-type: none"> • 85mm (3 3/8") Side Height • Integrated drawer slide and side 	<ul style="list-style-type: none"> • Height adjustment $\pm 2.0\text{mm}$ via cam • Side adjustment $\pm 1.5\text{mm}$ 	26
	Zargen 6026 <ul style="list-style-type: none"> • 85mm (3 3/8") Side Height • Integrated drawer slide and side 	<ul style="list-style-type: none"> • Height adjustment $\pm 2.0\text{mm}$ • Side adjustment $\pm 1.5\text{mm}$ 	28

ZBox & Zargen

Table of Content

	Description	Adjustment	Page
	<p>Zargen 6035</p> <ul style="list-style-type: none"> • 43mm (1 11/16") Side Height • Integrated drawer slide and side 	<ul style="list-style-type: none"> • Height adjustment $\pm 2.0\text{mm}$ via cam • Side adjustment $\pm 1.5\text{mm}$ 	30
	<p>Zargen Soft-close</p> <ul style="list-style-type: none"> • Liquid damper for improved performance 	<ul style="list-style-type: none"> • Height adjustment $\pm 2\text{mm}$ via elongated hole 	32
	<p>6100 Railing System</p> <ul style="list-style-type: none"> • Railing System • For use with all ZBox and Zargen drawers • Allows end user to customize storage space 		34
	<p>Pendaflex File Railing</p> <ul style="list-style-type: none"> • Three file systems available • For use with all ZBox and Zargen drawers • Easy installation 	<ul style="list-style-type: none"> • Accommodates letter and legal size folders 	35
	<p>Accessories and Assembly Aids</p>		38
	<p>Machinery</p> <ul style="list-style-type: none"> • Grass PRO1 <ul style="list-style-type: none"> • Boring and insertion machine • Functional design • Easy maintenance • ZRam <ul style="list-style-type: none"> • For drawer assembly • Activated by air • For ZBox and Zargen assembly 		42

Features and Benefits

ZBox

Features



- Integrated side mount ball bearing drawer slide and metal drawer side
- Ball bearing telescopic full extension
- Hold-in detent ensures drawers stay closed
- Easy lever disconnect for removal of drawer box from cabinet member
- Drawer side - white epoxy finish; Drawer slide - zinc coated steel
- Load capacity: 100 lb dynamic, 100 lb static
- Adjustments: Cam Height $\pm 2\text{mm}$, Side $\pm 1.5\text{mm}$
- Zargen is made in the USA, ZBox is assembled in the USA

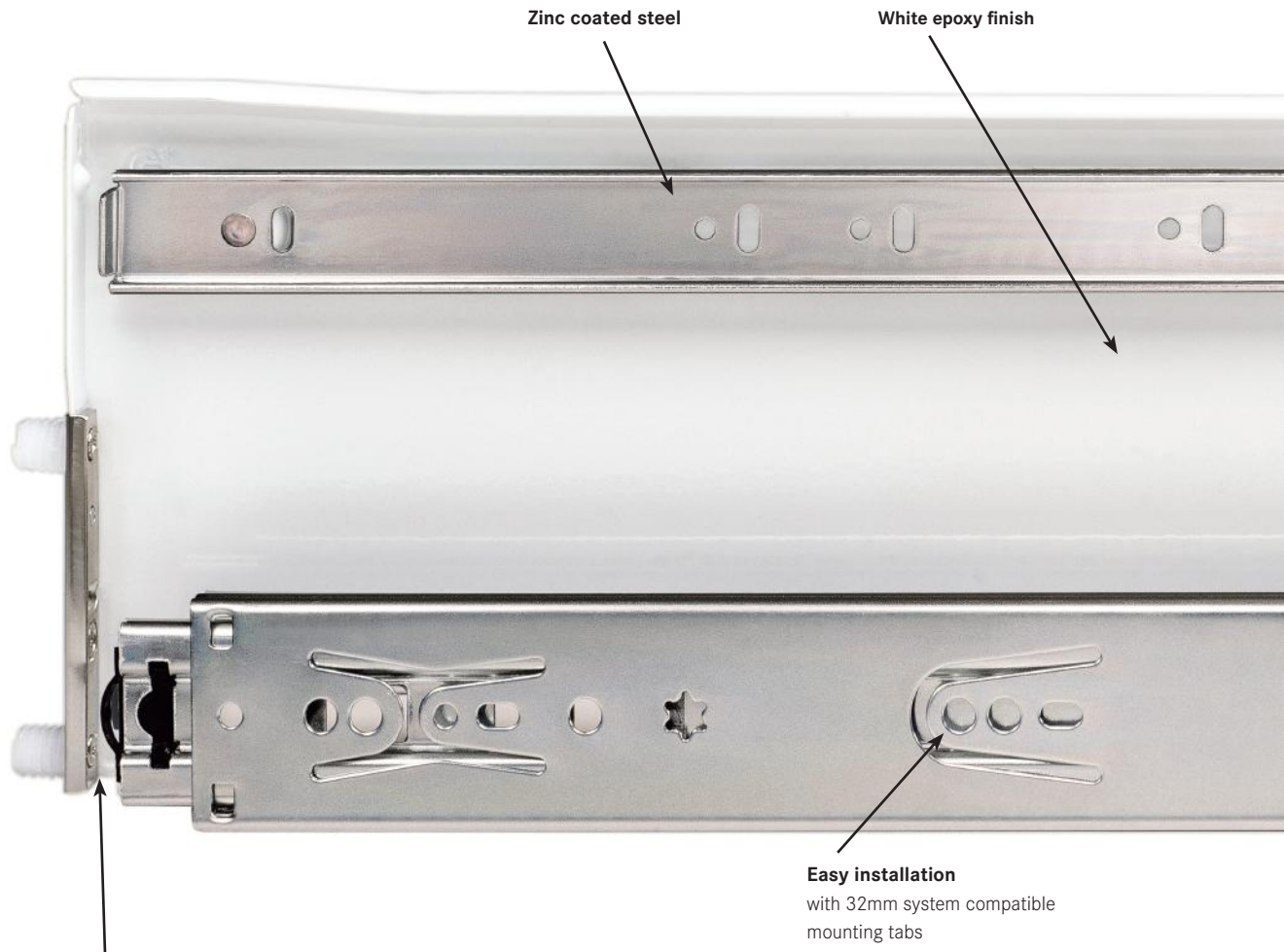

Adjustment via integrated front fixing bracket

Height adjustment $\pm 2\text{mm}$
Side adjustment $\pm 1.5\text{mm}$

ZBox combines the performance of ball bearing smoothness with the strength and adjustability of the Zargen Drawer System. A combination backed by GRASS.

Features

- Frameless or face frame application
- Zargen side: white epoxy finish
- Ball bearing slide: zinc coated steel
- Continuous bearings ensure smooth running performance
- Manufactured from cold rolled steel
- Face frame rear mounting bracket available
- Meets and exceeds ANSI/BHMA A156.9 Standard, Grade 1
- Patented design

Release lever for easy drawer removal

Suitable for face frame and frameless cabinets



Three drawer heights with integrated drawer side and cabinet member

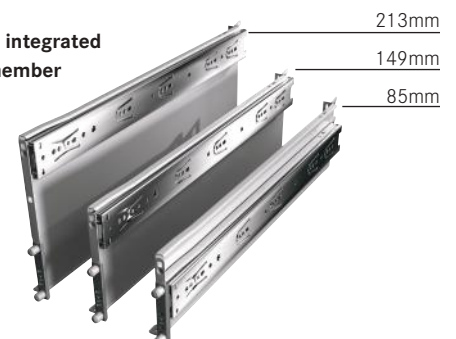

Technical Information

ZBox

Adjustment Features 6423, 6223

- 1 Height Adjustment: Loosen screws 2 slightly. Adjust screw 1 (adjustment ± 2 mm). Tighten screws 2.
- 2 Side Adjustment: Loosen screws 2 slightly. Adjust front to required position (adjustment range ± 1.5 mm). Tighten screws 2.

After adjusting front panel, mount fixing screw

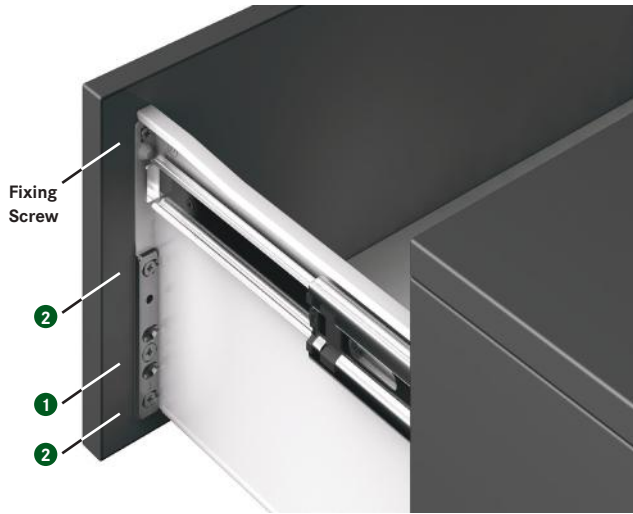

Adjustment Features 6023

- 1 Height Adjustment: Loosen screws 2 slightly. Adjust screw 1 (adjustment ± 2 mm). Tighten screws 2.
- 2 Side Adjustment: Loosen screws 2 slightly. Adjust front to required position (adjustment range ± 1.5 mm). Tighten screws 2.



System Organization

A unique feature of the ZBox System is its universal adaptability to Zargen Accessories. The 6100 railing system offers function, drawer space utilization, and economy.

Drawer with railing 6 100



Weight Capacities per Pair of Slides

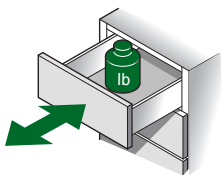

ZBox: 100 lb dynamic load rating, 100 lb static load rating

ZBox meets and exceeds the minimum requirements of ANSI/BHMA A156.9 Standard, Grade 1

Patented Design

ZBox

Cabinet Boring Specifications

Face Frame

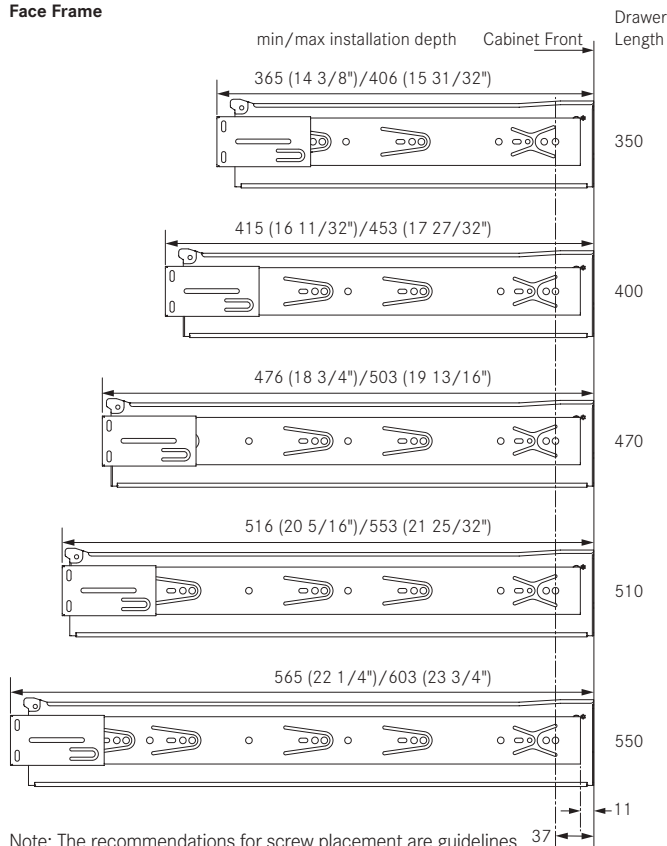

Note: The recommendations for screw placement are guidelines only. Installers need to ensure that the cabinet wall is adequate.

Frameless

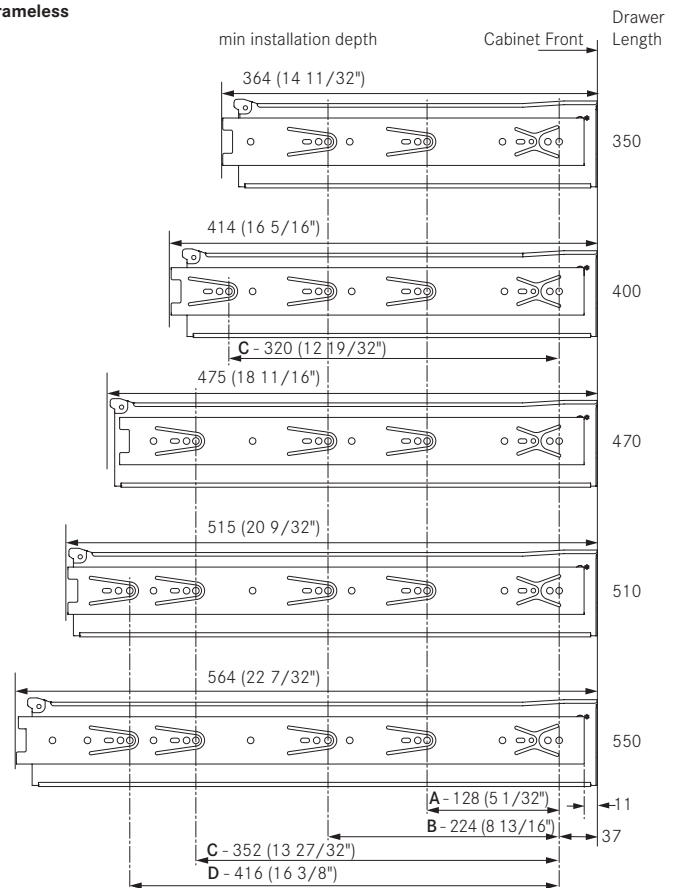

Drawer Length	Slide Travel	Screw Hole Locations				Face Frame		Frameless
		A	B	C	D	Min	Max	Min
350 (13 3/4")	350	128	224	-	-	365 (14 3/8")	406 (15 31/32")	364 (14 11/32")
400 (15 3/4")	400	128	224	320	-	415 (16 11/32")	453 (17 27/32")	414 (16 5/16")
470 (18 1/2")	450	128	224	352	-	476 (18 3/4")	503 (19 13/16")	475 (18 11/16")
510 (20 1/16")	500	128	224	352	416	516 (20 5/16")	553 (21 25/32")	515 (20 9/32")
550 (21 5/8")	550	128	224	352	416	565 (22 1/4")	603 (23 3/4")	564 (22 7/32")

Removing the Drawer



Pull out drawer to expose the release lever mechanism

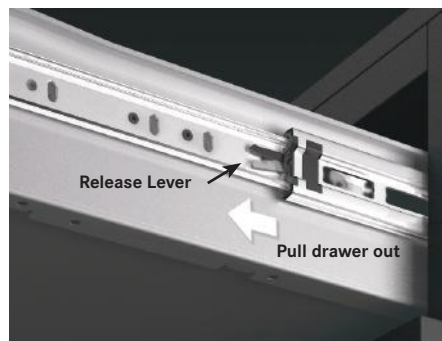

Easy Release Lever:
Right Side - push up; Left Side - push down
Pull out the drawer



Remove drawer

ZBox 6423

213mm (8 3/8") Side Height



- Integrated side mount ball bearing drawer slide and metal drawer side
- Ball bearing telescopic full extension
- Hold-in detent ensures drawers stay closed
- Easy lever disconnect for removal of drawer box from cabinet member
- Drawer side – white epoxy finish; Drawer slide – zinc coated steel
- Load capacity: 100 lb dynamic, 100 lb static
- Adjustments: Cam Height $\pm 2\text{mm}$, Side $\pm 1.5\text{mm}$
- Zargen made in the USA, ZBox assembled in USA

ZBox 6423 Full Extension Slide, 100 lbs



Description	Drawer Length	Item No.	PU
ZBox 6423/350	350 (13 3/4")	30144-03	5
ZBox 6423/400	400 (15 3/4")	30145-03	5
ZBox 6423/470	470 (18 1/2")	30146-03	5
ZBox 6423/510	510 (20 1/16")	30147-03	5
ZBox 6423/550	550 (21 5/8")	30148-03	5

Drawer Length	Bottom Panel Length		Extension
	16mm (5/8") Back Panel	19mm (3/4") Back Panel	
350 (13 3/4")	331 (13 1/16")	328 (12 15/16")	350 (13 3/4")
400 (15 3/4")	381 (15")	378 (14 7/8")	400 (15 3/4")
470 (18 1/2")	451 (17 3/4")	448 (17 5/8")	450 (17 3/4")
510 (20 1/16")	491 (19 5/16")	488 (19 3/16")	500 (19 11/16")
550 (21 5/8")	531 (20 7/8")	528 (20 13/16")	550 (21 5/8")

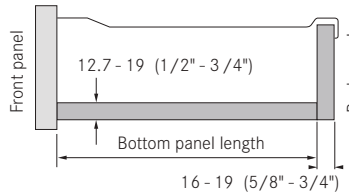

Face Frame Brackets



Description	Item No.	PU
1 Face frame rear mount bracket	30200-09	100
2 Inset bracket set*	13901-37	1
Inset bracket set*	13901-08	50

*See page 41 for installation instructions.

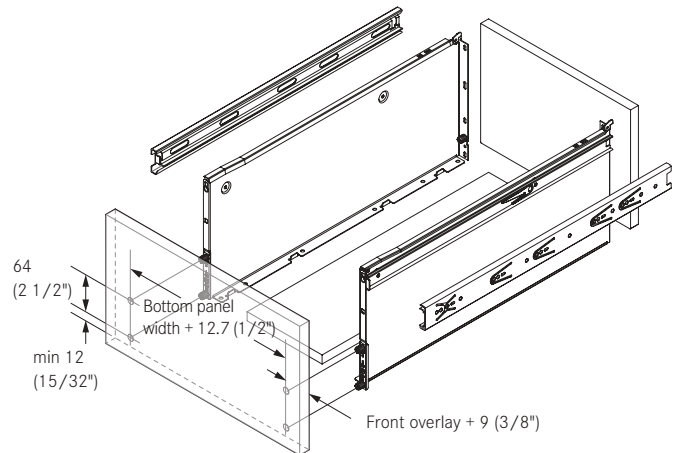

PU – Packaging unit

ZBox 6223

149mm (5 7/8") Side Height



- Integrated side mount ball bearing drawer slide and metal drawer side
- Ball bearing telescopic full extension
- Hold-in detent ensures drawers stay closed
- Easy lever disconnect for removal of drawer box from cabinet member
- Drawer side – white epoxy finish; Drawer slide – zinc coated steel
- Load capacity: 100 lb dynamic, 100 lb static
- Adjustments: Cam Height $\pm 2\text{mm}$, Side $\pm 1.5\text{mm}$
- Zargen made in the USA, ZBox assembled in USA

ZBox 6223 Full Extension Slide, 100 lbs



Description	Drawer Length	Item No.	PU
ZBox 6223/350	350 (13 3/4")	30139-03	5
ZBox 6223/400	400 (15 3/4")	30140-03	5
ZBox 6223/470	470 (18 1/2")	30141-03	5
ZBox 6223/510	510 (20 1/16")	30142-03	5
ZBox 6223/550	550 (21 5/8")	30143-03	5

Drawer Length	Bottom Panel Length		Extension
	16mm (5/8") Back Panel	19mm (3/4") Back Panel	
350 (13 3/4")	331 (13 1/16")	328 (12 15/16")	350 (13 3/4")
400 (15 3/4")	381 (15")	378 (14 7/8")	400 (15 3/4")
470 (18 1/2")	451 (17 3/4")	448 (17 5/8")	450 (17 3/4")
510 (20 1/16")	491 (19 5/16")	488 (19 3/16")	500 (19 11/16")
550 (21 5/8")	531 (20 7/8")	528 (20 13/16")	550 (21 5/8")

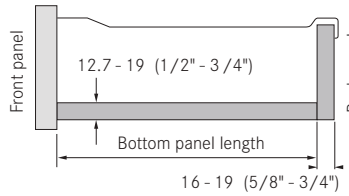

Face Frame Brackets



Description	Drawer Length	Item No.	PU
1 Face frame rear mount bracket		30200-09	100
2 Inset bracket set*		13901-37	1
Inset bracket set*		13901-08	50

*See page 41 for installation instructions.

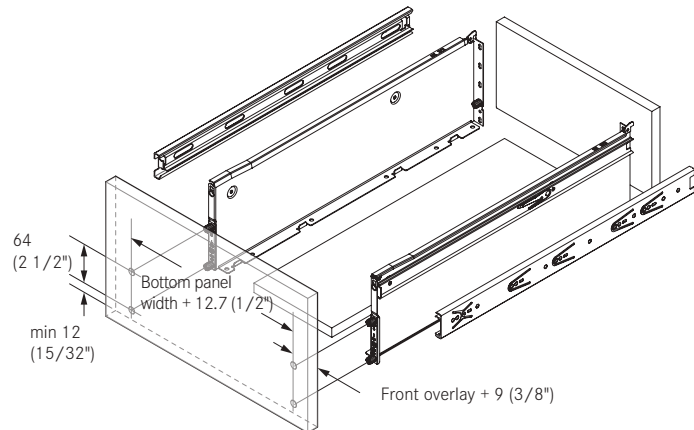

PU – Packaging unit

Drawer Back and Bottom Measurements

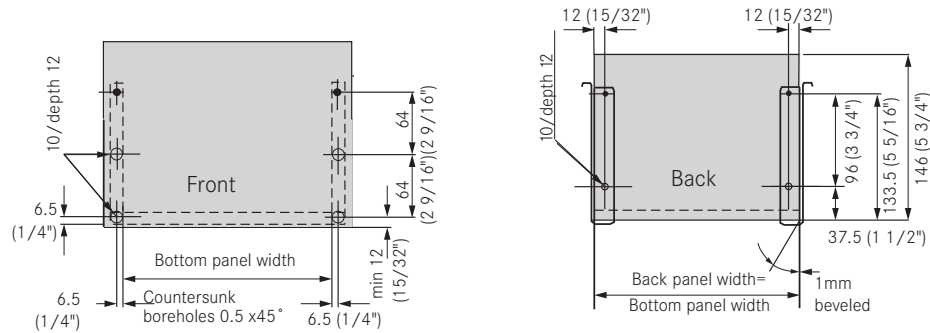

Drawer Installation Measurements

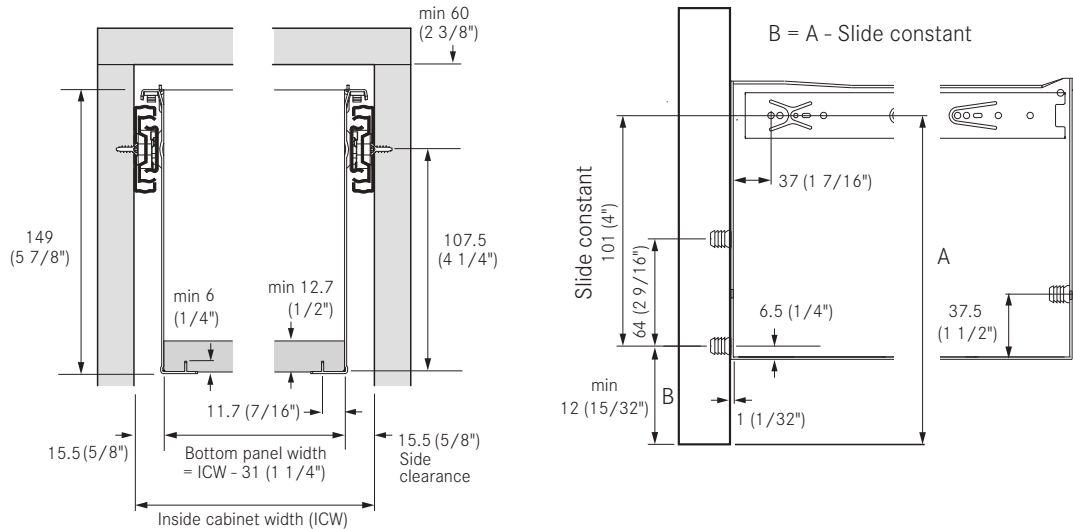

Face Frame Installation

For Face Frame Cabinetry Use:

Back

- Attach face frame rear mounting brackets (Item # 30200-09) to slide

Front - Setback=37mm

- Use Inset bracket (Item # 13901-37) or
- Block out the face frame
- See page 41 for installation instructions

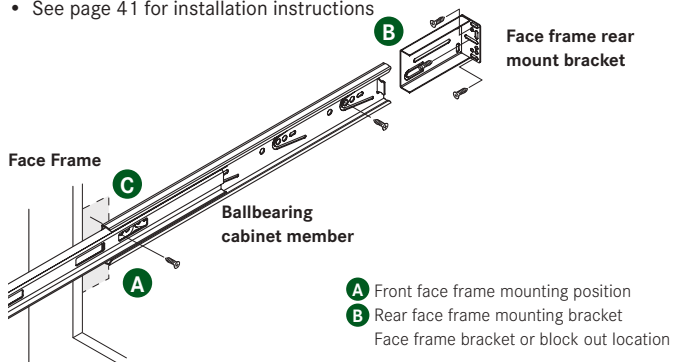

Adjustment Features 6423, 6223

- 1 Height Adjustment:**
 Loosen screws 2 slightly
 Adjust screw 1 (adjustment ±2mm).
 Tighten screws 2.
- 2 Side Adjustment:**
 Loosen screws 2 slightly.
 Adjust front to required position (adjustment range ±1.5mm).
 Tighten screws 2.

After adjusting front panel, mount fixing screw.

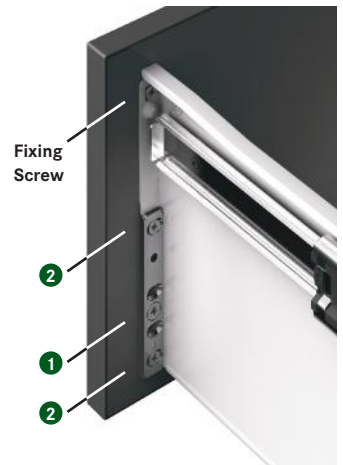

ZBox 6023

85mm (3 3/8") Side Height

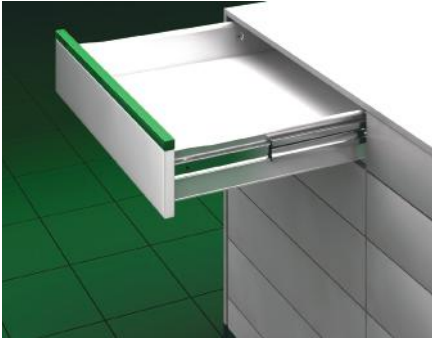

- Integrated side mount ball bearing drawer slide and metal drawer side
- Ball bearing telescopic full extension
- Hold-in detent ensures drawers stay closed
- Easy lever disconnect for removal of drawer box from cabinet member
- Drawer side – white epoxy finish; Drawer slide – zinc coated steel
- Load capacity: 100 lb dynamic, 100 lb static
- Adjustments: Cam Height $\pm 2\text{mm}$, Side $\pm 1.5\text{mm}$
- Zargen made in the USA, ZBox assembled in USA

ZBox 6023 Full Extension Slide, 100 lbs



Description	Drawer Length	Item No.	PU
ZBox 6023/350	350 (13 3/4")	30134-03	5
ZBox 6023/400	400 (15 3/4")	30135-03	5
ZBox 6023/470	470 (18 1/2")	30136-03	5
ZBox 6023/510	510 (20 1/16")	30137-03	5
ZBox 6023/550	550 (21 5/8")	30138-03	5

Drawer Length	Bottom Panel Length		Extension
	16mm (5/8") Back Panel	19mm (3/4") Back Panel	
350 (13 3/4")	331 (13 1/16")	328 (12 15/16")	350 (13 3/4")
400 (15 3/4")	381 (15")	378 (14 7/8")	400 (15 3/4")
470 (18 1/2")	451 (17 3/4")	448 (17 5/8")	450 (17 3/4")
510 (20 1/16")	491 (19 5/16")	488 (19 3/16")	500 (19 11/16")
550 (21 5/8")	531 (20 7/8")	528 (20 13/16")	550 (21 5/8")

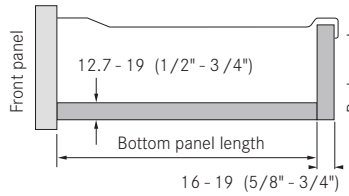

Face Frame Brackets



Description	Item No.	PU
1 Face frame rear mount bracket	30200-09	100
2 Inset bracket set*	13901-37	1
Inset bracket set*	13901-08	50

*See page 41 for installation instructions.

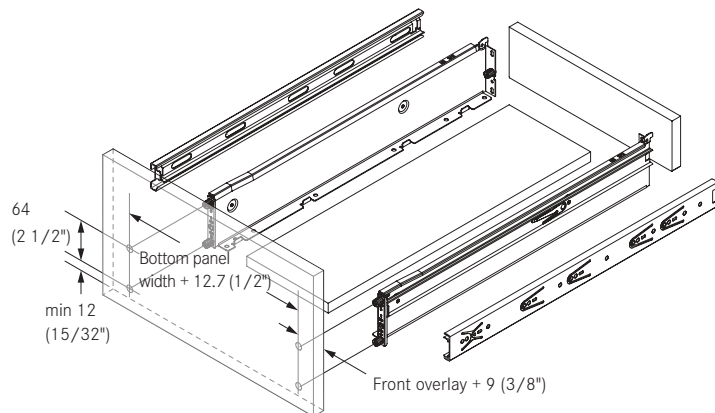

PU – Packaging unit

Drawer Back and Bottom Measurements

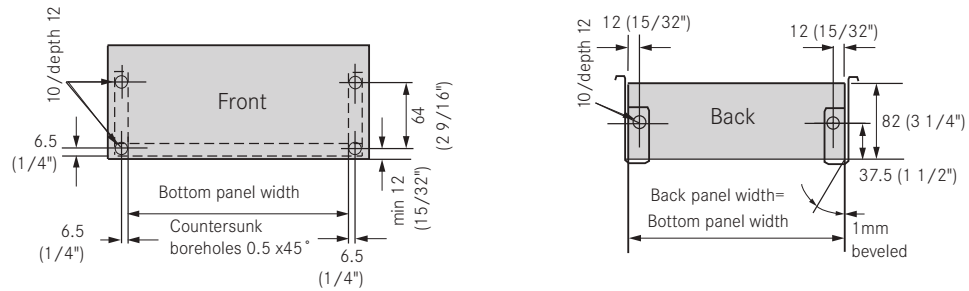

Drawer Installation Measurements

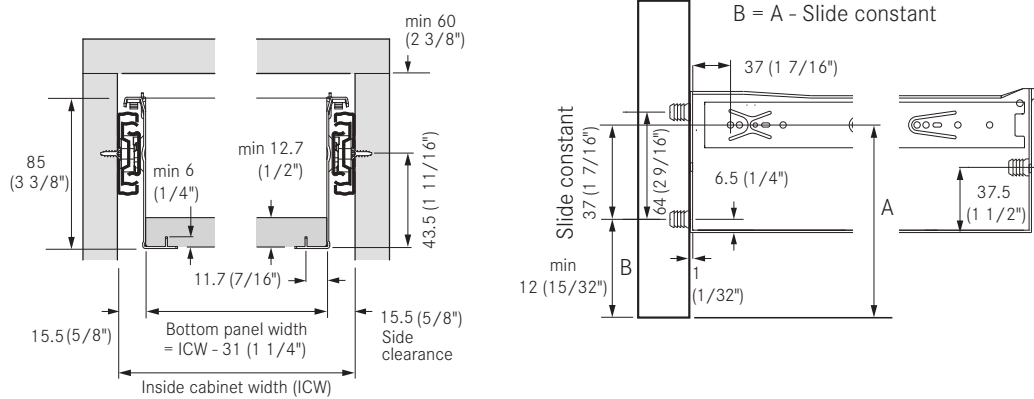

Face Frame Installation

For Face Frame Cabinetry Use:

Back

- Attach face frame rear mounting brackets (Item # 30200-09) to slide

Front - Setback=37mm

- Use Inset bracket (Item # 13901-37) or
- Block out the face frame
- See page 41 for installation instructions

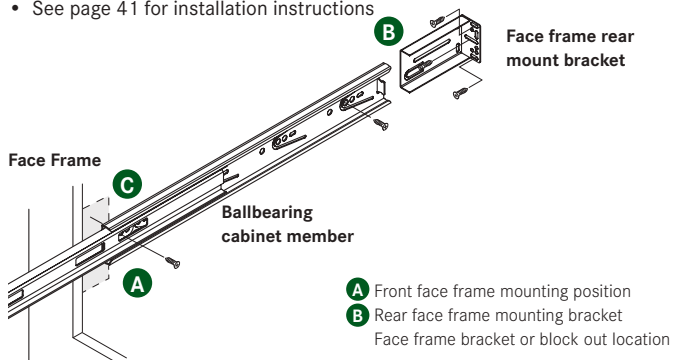

Adjustment Features 6023

- 1 Height Adjustment:**
Loosen screws 2 slightly
Adjust screw 1 (adjustment $\pm 2\text{mm}$).
Tighten screws 2.
- 2 Side Adjustment:**
Loosen screws 2 slightly.
Adjust front to required position (adjustment range $\pm 1.5\text{mm}$).
Tighten screws 2.

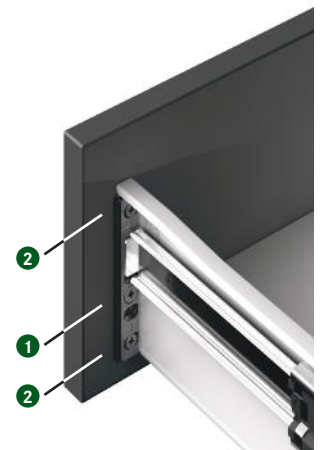

Features and Benefits

Zargen

Features



- Integrated drawer slide and drawer side
- White epoxy finish
- Load capacity: 100 lb dynamic, 100 lb static
- Installation width 15.5mm (5/8")
- Made in the USA

Quick Assembly
with integrated front
fixing brackets

Built in drawer front bumpers
protect the drawer front during closing

Side adjustment
±1.5mm

Height adjustment
±2mm

Versatile. Reliable. Proven.
Zargen delivers superior performance
with tried-and-tested technology.

Features

- Available in five drawer heights
 - 43mm (1 11/16")
 - 85mm (3 3/8")
 - 117mm (4 5/8")
 - 149mm (5 7/8")
 - 213mm (8 3/8")

Double stop

on drawer member locks the drawer safely in the open position

Parallel closing action

keeps the drawer front properly aligned

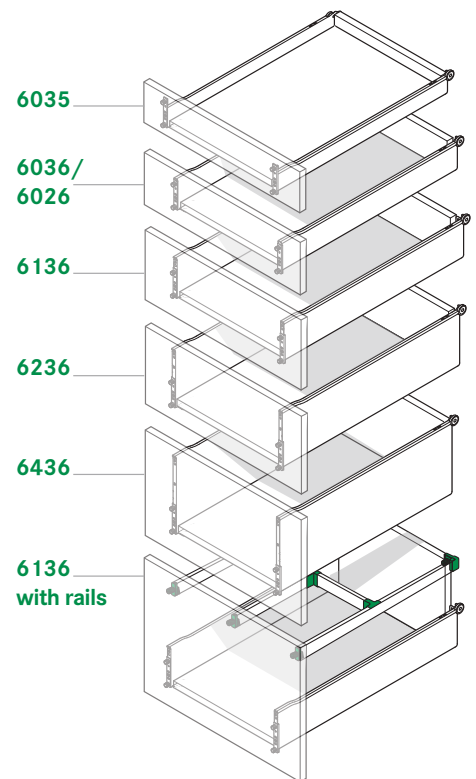

Technical Information

Zargen

Double Stop Rollers Built-in Stop

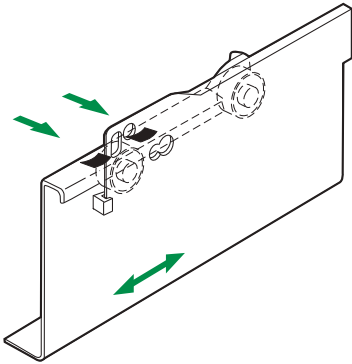

The double stop prevents the drawer from falling out while being extended. In addition, the drawer can be locked in the open position.

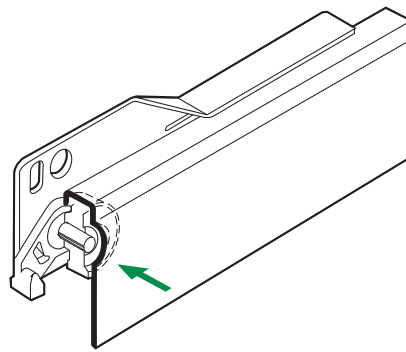

Special rollers provide lateral stability and a smooth glide. The rollers are tested for durability, and washers behind the rollers ensure stability.

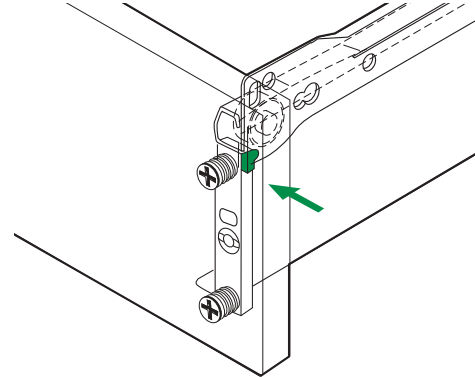

The integrated drawer stop protects the drawer front from impact during closing. Furthermore, it acts as a shock absorber and a self-alignment feature for the drawer fronts.

Closing

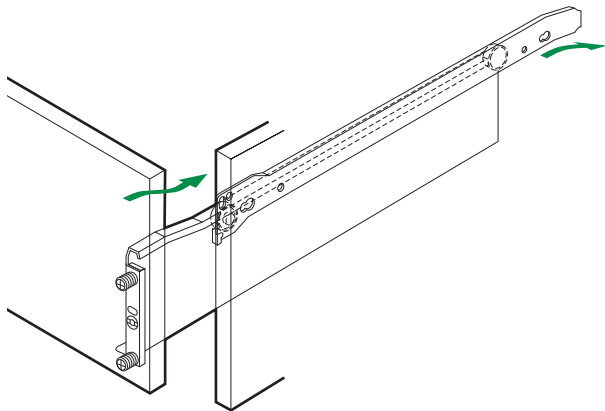

Self-Closing From a range of 60mm (2 3/8") out, the drawer closes quietly and smoothly. Drawers closed with force will not bounce back.

Minimum Reveal Minimum reveals are required between fronts due to the specifically formed closing action.

Parallel Closing The parallel closing action keeps the drawer front properly aligned with the cabinet front. Cabinet members feature elongated holes for height adjustment.

Adjustment Features 6036, 6035 Adjustment Features 6436, 6236, 6136

Height Adjustment:

Loosen screws 2 slightly. Adjust screw 1 (adjustment $\pm 2\text{mm}$). Tighten screws 2.

Side Adjustment:

Loosen screws 2 slightly. Adjust front to required position (adjustment range $\pm 1.5\text{mm}$). Tighten screws 2.

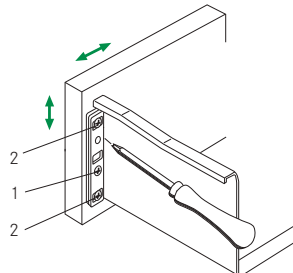

Height Adjustment:

Loosen screws 2 slightly. Adjust screw 1 (adjustment $\pm 2\text{mm}$). Tighten screws 2.

Side Adjustment:

Loosen screws 2 slightly. Adjust front to required position (adjustment range $\pm 1.5\text{mm}$). Tighten screws 2.

After adjusting front panel, mount fixing screw

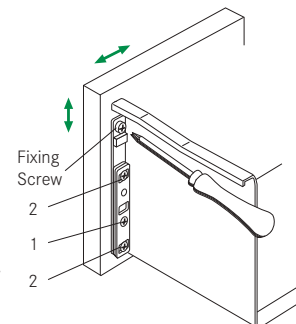

Weight Capacities per Pair of Slides

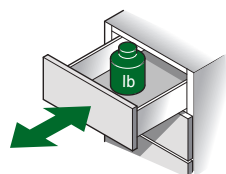

Zargen: 100 lb dynamic load rating; 100 lb static load rating

Zargen meets and exceeds the minimum requirements of ANSI/BHMA A156.9 Standard, Grade 1

Cabinet Member

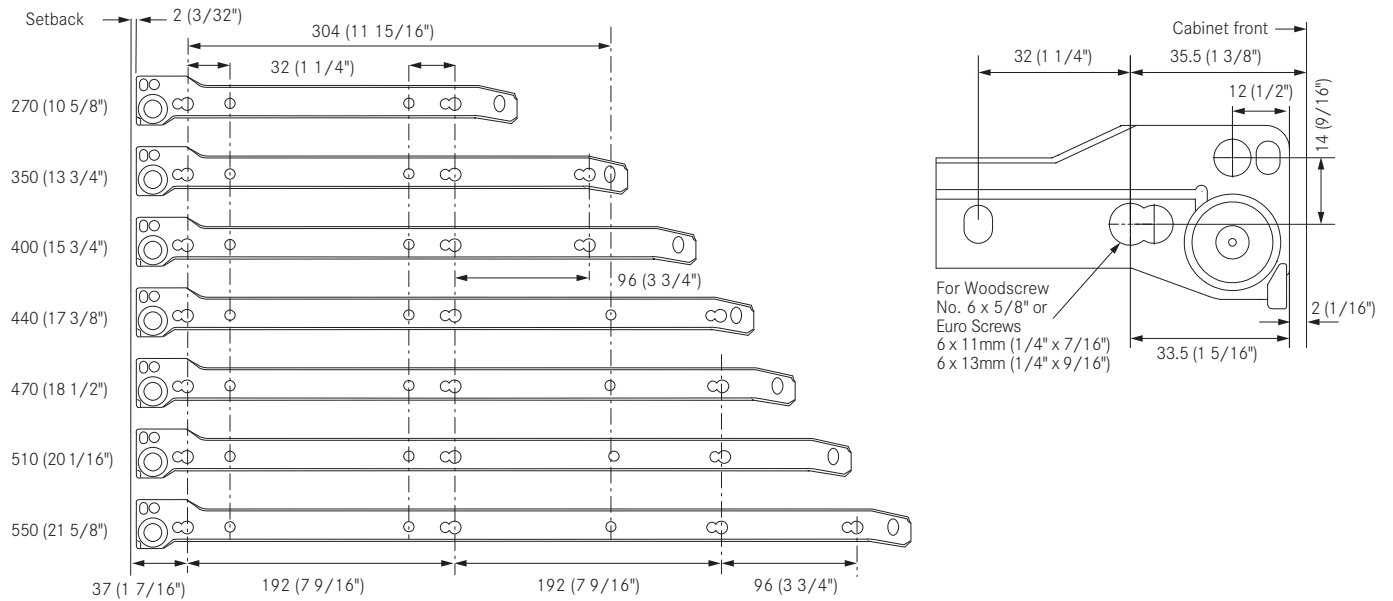

To simplify installation of the cabinet member, a unique double-hole pattern for 32mm and 37mm setback has been developed.

Installation

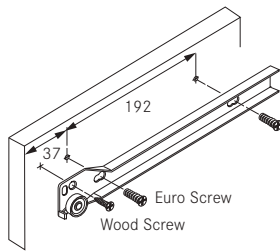

With Euro Screws

(Flat Head Phillips)
the cabinet member can be fastened into a pre-drilled 32mm hole system. See cabinet member drawing to the left for all fastening positions.

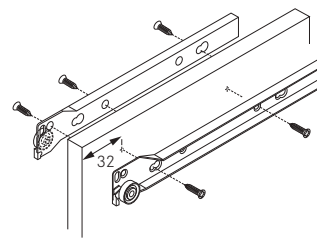

With Wood Screws

(#6x5/8" Flat Head Phillips)
the cabinet member is screwed directly on the end panel. To guarantee precise positioning, pre-center with a Grass pilot drill. For wood screws, use the front section of the double hole.

Captive Rollers

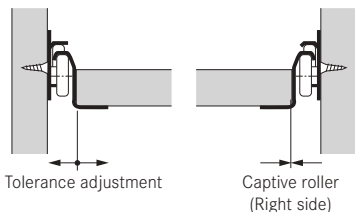

System Organization

Slide with railing (6036, 6100)

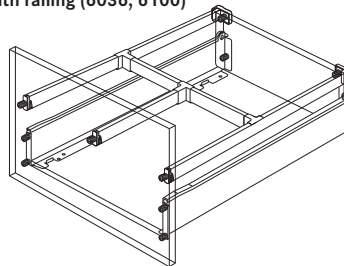

A unique feature of the Zargen System is its universal adaptability in cabinetry. The system offers function, drawer space utilization and economy. With regular drawers, inset pull-outs, divider railings and more the Zargen System provides a variety of organizational solutions.

Manufacturing often is accompanied by tolerance problems. To avoid this situation, Grass slides are designed to eliminate side movement of the drawer. After installation, the right drawer member blends perfectly with the right cabinet member for guidance; the left side allows for cutting tolerance of the drawer and the cabinet components.

Zargen 6436

213mm (8 3/8") Side Height



- Integrated drawer slide and drawer side
- Self-closing feature with 60mm (2 3/8") closing range
- Built-in drawer front bumpers
- Quick assembly through dowelled and integrated front fixing brackets
- White epoxy finish
- Tolerance adjustment 2mm (3/32")
- Load capacity: 100 lb
- Adjustments: Cam height (± 2 mm), side (± 1.5 mm)
- Made in the USA

Zargen 6436 slide, 100 lb (45 kg)



Description	Slide Length	Item No.	PU
Zargen 6436/350	350 (13 3/4")	22910-03	5
Zargen 6436/400	400 (15 3/4")	22911-03	5
Zargen 6436/440	440 (17 3/8")	22708-03	5
Zargen 6436/470	470 (18 1/2")	22709-03	5
Zargen 6436/510	510 (20 1/16")	22710-03	5
Zargen 6436/550	550 (21 5/8")	22711-03	5
Zargen 6436/510	510 (20 1/16")	22710-12	200
Zargen 6436/550	550 (21 5/8")	22711-12	200

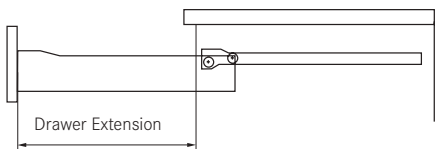
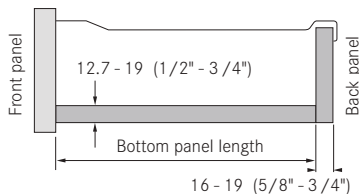

Slide Length	Bottom Panel Length		Extension	
	16mm (5/8") Back Panel	19mm (3/4") Back Panel	Single Stop	Double Stop
350 (13 3/4")	331 (13 1/16")	328 (12 15/16")	280 (11")	-
400 (15 3/4")	381 (15")	378 (14 7/8")	300 (11 13/16")	314 (12 3/8")
440 (17 3/8")	421 (16 9/16")	418 (16 7/16")	340 (13 3/8")	354 (13 15/16")
470 (18 1/2")	451 (17 3/4")	448 (17 5/8")	370 (14 9/16")	384 (15 1/8")
510 (20 1/16")	491 (19 5/16")	488 (19 3/16")	410 (16 1/8")	424 (16 11/16")
550 (21 5/8")	531 (20 7/8")	528 (20 13/16")	450 (17 11/16")	464 (18 1/4")

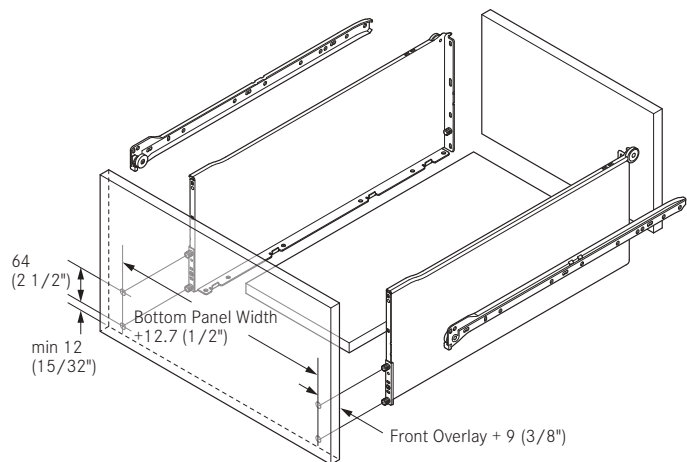

PU - Packaging unit

Drawer Back and Bottom Measurements

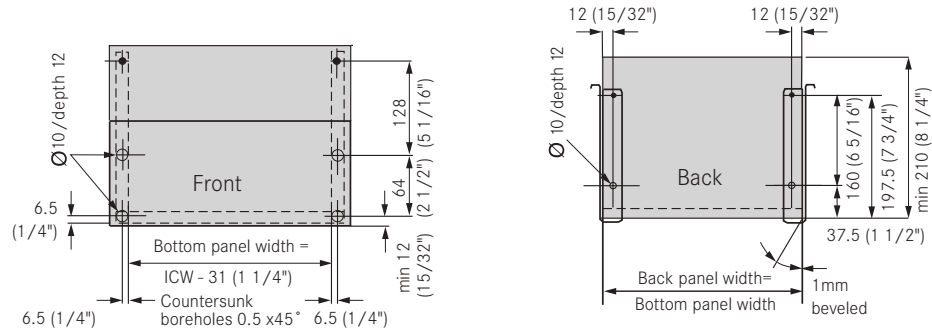

Drawer Installation Measurements

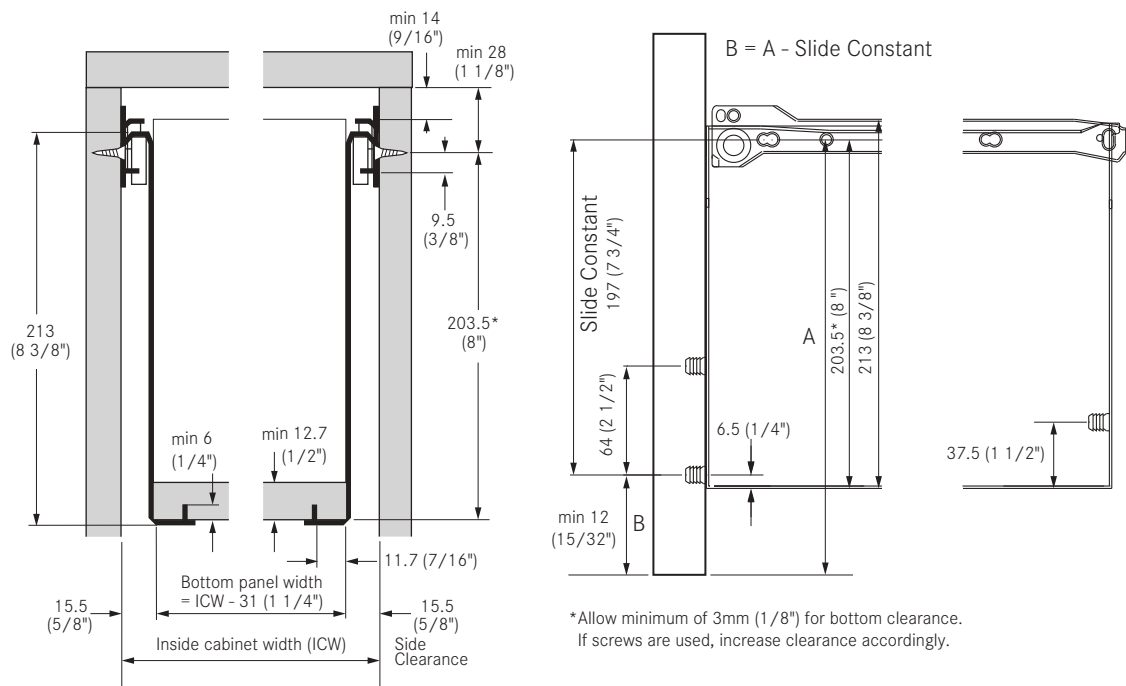

Drawer slide attachment:

Wood screws #6 x 5/8 FHP

Euro screw lengths 18mm, 13mm, 7.5mm

Bottom panel thickness: 12.7 - 19mm (1/2" - 3/4")

Back panel thickness: 16 - 19mm (5/8" - 3/4")

Back panel height: min 210mm (8 1/4")

All dimensions in millimeters.

Zargen 6236

149mm (5 7/8") Side Height



- Integrated drawer slide and drawer side
- Self-closing feature with 60mm (2 3/8") closing range
- Built-in drawer front bumpers
- Quick assembly through dowelled and integrated front fixing brackets
- White epoxy finish
- Tolerance adjustment 2mm (3/32")
- Load capacity: 100 lb
- Adjustments: Cam height (± 2 mm), side (± 1.5 mm)
- Made in the USA

Zargen 6236 slide, 100 lb (45 kg)



Description	Slide Length	Item No.	PU
Zargen 6236/350	350 (13 3/4")	22908-03	5
Zargen 6236/400	400 (15 3/4")	22909-03	5
Zargen 6236/440	440 (17 3/8")	22704-03	5
Zargen 6236/470	470 (18 1/2")	22705-03	5
Zargen 6236/510	510 (20 1/16")	22706-03	5
Zargen 6236/550	550 (21 5/8")	22707-03	5
Zargen 6236/350	350 (13 3/4")	22908-12	200
Zargen 6236/400	400 (15 3/4")	22909-12	200
Zargen 6236/440	440 (17 3/8")	22704-12	200
Zargen 6236/470	470 (18 1/2")	22705-12	200
Zargen 6236/510	510 (20 1/16")	22706-12	200
Zargen 6236/550	550 (21 5/8")	22707-12	200

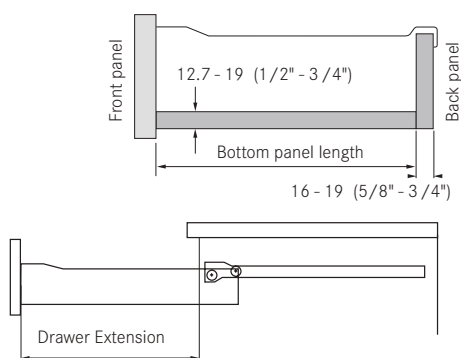

Slide Length	Bottom Panel Length		Extension	
	16mm (5/8") Back Panel	19mm (3/4") Back Panel	Single Stop	Double Stop
350 (13 3/4")	331 (13 1/16")	328 (12 15/16")	280 (11")	-
400 (15 3/4")	381 (15")	378 (14 7/8")	300 (11 13/16")	314 (12 3/8")
440 (17 3/8")	421 (16 9/16")	418 (16 7/16")	340 (13 3/8")	354 (13 15/16")
470 (18 1/2")	451 (17 3/4")	448 (17 5/8")	370 (14 9/16")	384 (15 1/8")
510 (20 1/16")	491 (19 5/16")	488 (19 3/16")	410 (16 1/8")	424 (16 11/16")
550 (21 5/8")	531 (20 7/8")	528 (20 13/16")	450 (17 11/16")	464 (18 1/4")

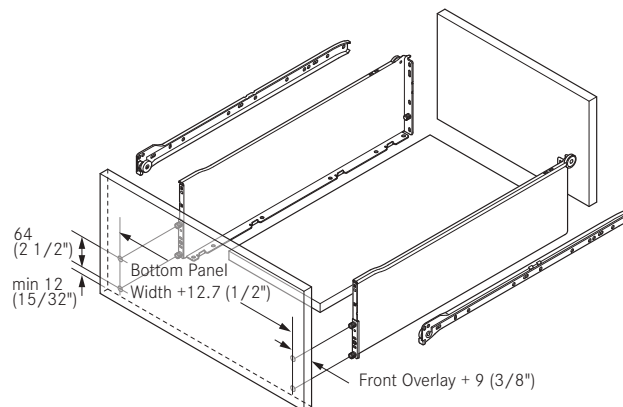

PU - Packaging unit

Drawer Back and Bottom Measurements

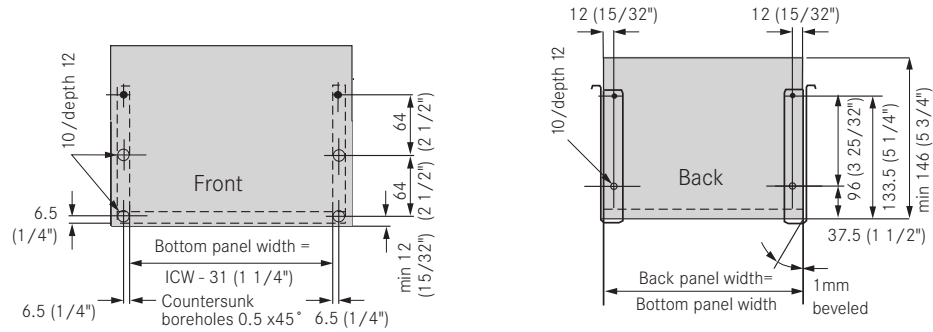

Drawer Installation Measurements

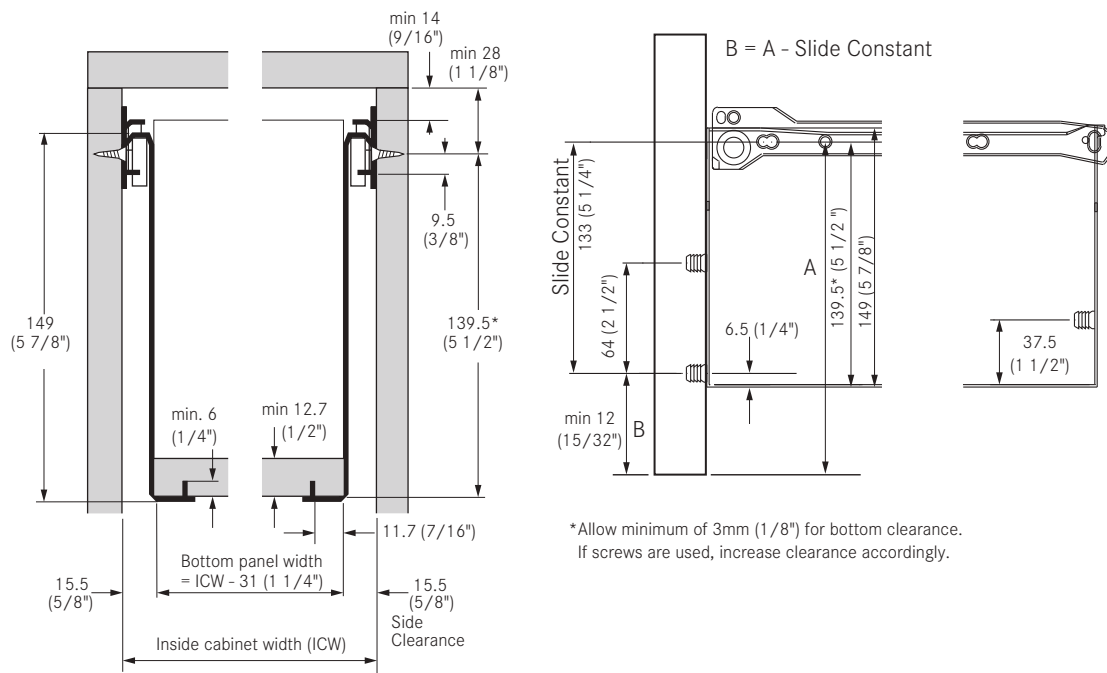

Drawer slide attachment:

Wood screws #6 x 5/8 FHP

Euro screw lengths 18mm, 13mm, 7.5mm

Bottom panel thickness: 12.7 - 19mm (1/2" - 3/4")

Back panel thickness: 16 - 19mm (5/8" - 3/4")

Back panel height: min 146mm (5 3/4")

All dimensions in millimeters.

Zargen 6136

117mm (4 5/8") Side Height



- Integrated drawer slide and drawer side
- Self-closing feature with 60mm (2 3/8") closing range
- Built-in drawer front bumpers
- Quick assembly through dowelled and integrated front fixing brackets
- White epoxy finish
- Tolerance adjustment 2mm (3/32")
- Load capacity: 100 lb
- Adjustments: Cam height (± 2 mm), side (± 1.5 mm)
- Made in the USA

Zargen 6136 slide, 100 lb (45 kg)



Description	Slide Length	Item No.	PU
Zargen 6136/350	350 (13 3/4")	22906-03	5
Zargen 6136/400	400 (15 3/4")	22907-03	5
Zargen 6136/440	440 (17 3/8")	22700-03	5
Zargen 6136/470	470 (18 1/2")	22701-03	5
Zargen 6136/510	510 (20 1/16")	22702-03	5
Zargen 6136/550	550 (21 5/8")	22703-03	5
Zargen 6136/400	400 (15 3/4")	22907-12	200
Zargen 6136/510	510 (20 1/16")	22702-12	200
Zargen 6136/550	550 (21 5/8")	22703-12	200

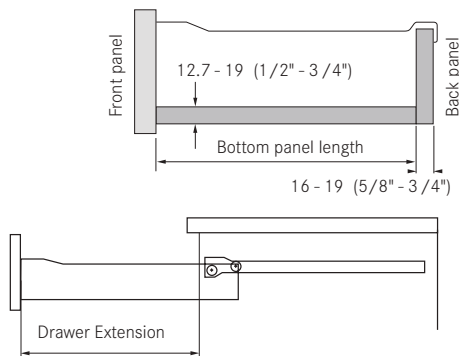

Slide Length	Bottom Panel Length		Extension	
	16mm (5/8") Back Panel	19mm (3/4") Back Panel	Single Stop	Double Stop
350 (13 3/4")	331 (13 1/16")	328 (12 15/16")	280 (11")	-
400 (15 3/4")	381 (15")	378 (14 7/8")	300 (11 13/16")	314 (12 3/8")
440 (17 3/8")	421 (16 9/16")	418 (16 7/16")	340 (13 3/8")	354 (13 15/16")
470 (18 1/2")	451 (17 3/4")	448 (17 5/8")	370 (14 9/16")	384 (15 1/8")
510 (20 1/16")	491 (19 5/16")	488 (19 3/16")	410 (16 1/8")	424 (16 11/16")
550 (21 5/8")	531 (20 7/8")	528 (20 13/16")	450 (17 11/16")	464 (18 1/4")

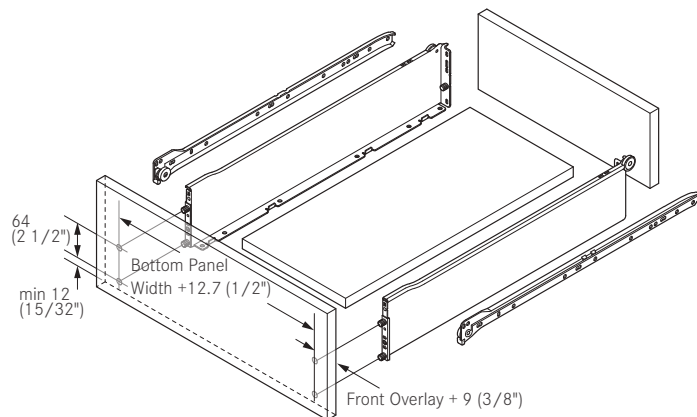

PU - Packaging unit

Drawer Back and Bottom Measurements

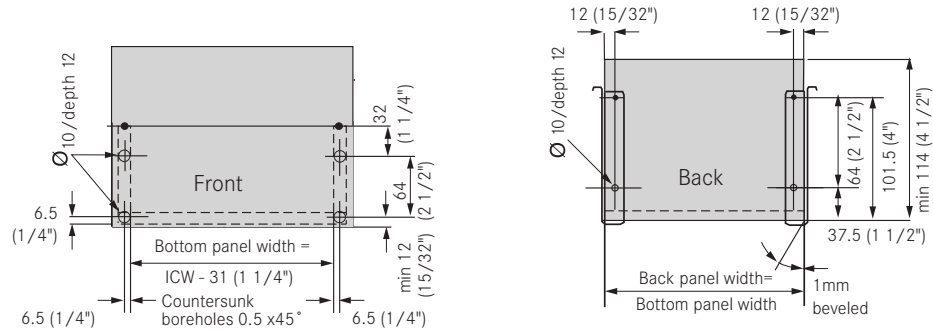

Drawer Installation Measurements

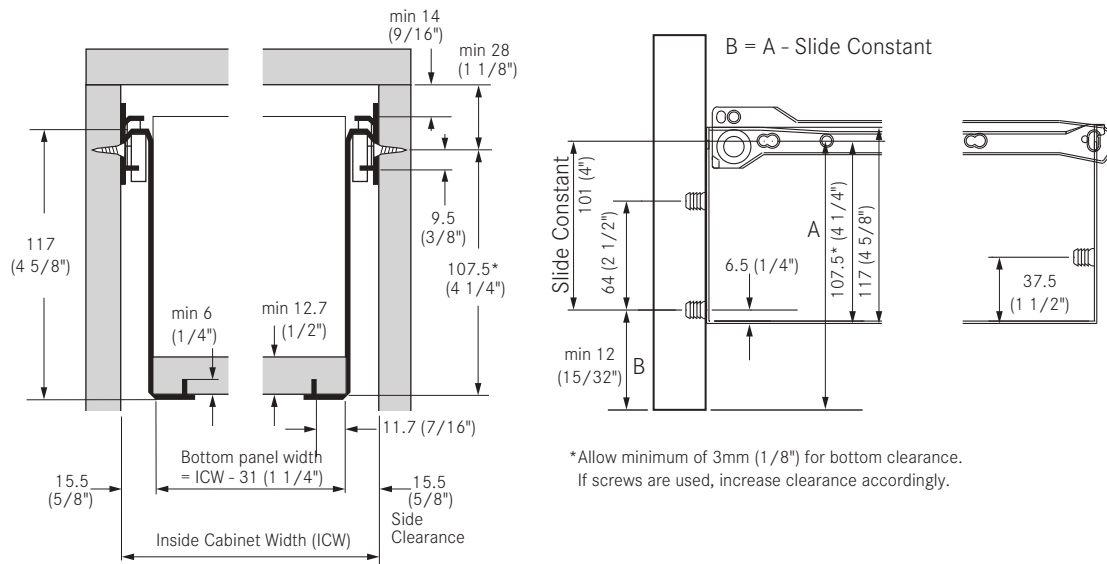

Drawer slide attachment:

Wood screws #6 x 5/8 FHP

Euro screw lengths 18mm, 13mm, 7.5mm

Bottom panel thickness: 12.7 - 19mm (1/2" - 3/4")

Back panel thickness: 16 - 19mm (5/8" - 3/4")

Back panel height: min 114mm (4 1/2")

All dimensions in millimeters.

Zargen 6036

85mm (3 3/8") Side Height



- Integrated drawer slide and drawer side
- Self-closing feature with 60mm (2 3/8") closing range
- Built-in drawer front bumpers
- Quick assembly through dowelled and integrated front fixing brackets
- White epoxy finish
- Tolerance adjustment 2mm (3/32")
- Load capacity: 100 lb
- Adjustments: Cam height (± 2 mm), side (± 1.5 mm)
- Made in the USA

Zargen 6036 slide, 100 lb (45 kg)



Description	Slide Length	Item No.	PU
Zargen 6036/270	270 (10 5/8")	11895-04	10
Zargen 6036/350	350 (13 3/4")	11896-04	10
Zargen 6036/400	400 (15 3/4")	12849-04	10
Zargen 6036/440	440 (17 3/8")	12850-04	10
Zargen 6036/470	470 (18 1/2")	12851-04	10
Zargen 6036/510	510 (20 1/16")	12852-04	10
Zargen 6036/550	550 (21 5/8")	11901-04	10
Zargen 6036/400	400 (15 3/4")	12849-16	400
Zargen 6036/440	440 (17 3/8")	12850-16	400
Zargen 6036/470	470 (18 1/2")	12851-16	400
Zargen 6036/510	510 (20 1/16")	12852-15	300
Zargen 6036/550	550 (21 5/8")	11901-15	300

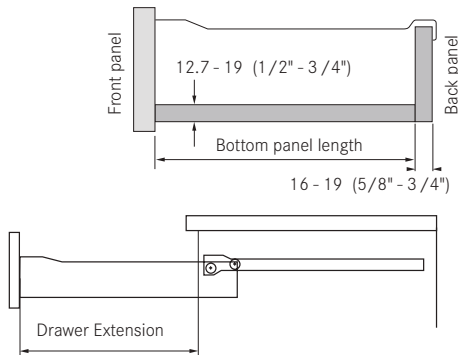

Slide Length	Bottom Panel Length		Extension	
	16mm (5/8") Back Panel	19mm (3/4") Back Panel	Single Stop	Double Stop
350 (13 3/4")	331 (13 1/16")	328 (12 15/16")	280 (11")	-
400 (15 3/4")	381 (15")	378 (14 7/8")	300 (11 13/16")	314 (12 3/8")
440 (17 3/8")	421 (16 9/16")	418 (16 7/16")	340 (13 3/8")	354 (13 15/16")
470 (18 1/2")	451 (17 3/4")	448 (17 5/8")	370 (14 9/16")	384 (15 1/8")
510 (20 1/16")	491 (19 5/16")	488 (19 3/16")	410 (16 1/8")	424 (16 11/16")
550 (21 5/8")	531 (20 7/8")	528 (20 13/16")	450 (17 11/16")	464 (18 1/4")

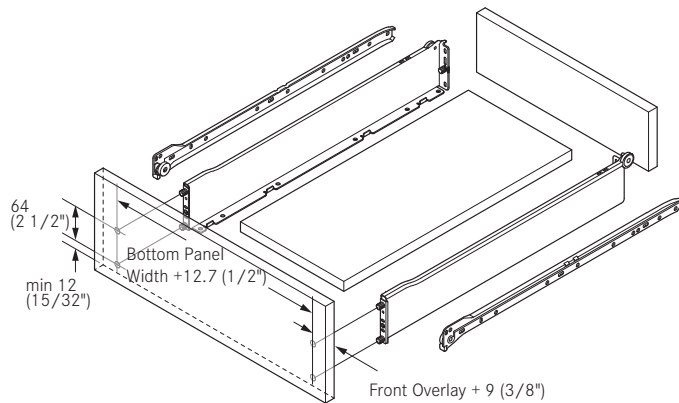

PU - Packaging unit

Drawer Back and Bottom Measurements

Drawer Back and Bottom Measurements with 6100 Railing Installation

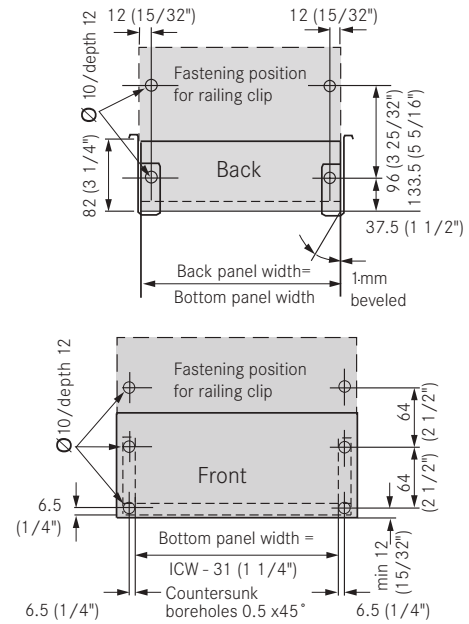
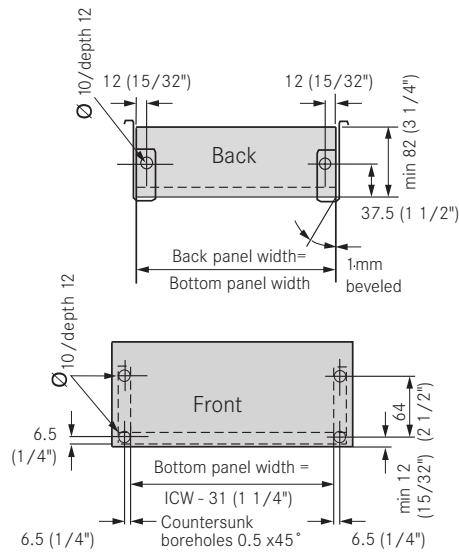

Drawer Installation Measurements

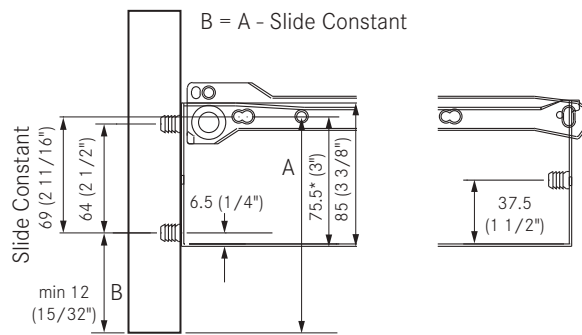
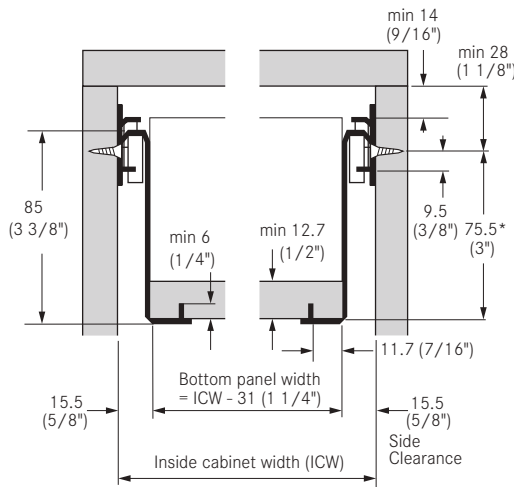

*Allow minimum of 3mm (1/8") for bottom clearance.
If screws are used, increase clearance accordingly.

Drawer slide attachment:

Wood screws #6 x 5/8 FHP

Euro screw lengths 18mm, 13mm, 7.5mm

Bottom panel thickness: 12.7 - 19mm (1/2" - 3/4")

Back panel thickness: 16 - 19mm (5/8" - 3/4")

Back panel height: $\min 82$ (3 1/4")

All dimensions in millimeters.

Zargen 6026

85mm (3 3/8") Side Height



- Integrated drawer slide and drawer side
- Self-closing feature with 60mm (2 3/8") closing range
- Built-in drawer front bumpers
- Quick assembly through dowelled and integrated front fixing brackets
- White epoxy finish
- Tolerance adjustment 2mm (3/32")
- Load capacity: 100 lb
- Adjustments: height (± 2 mm), side (± 1.5 mm)
- Made in the USA

Zargen 6026 slide, 100 lb (45 kg)



Description	Slide Length	Item No.	PU
Zargen 6026/270	270 (10 5/8")	17766-04	10
Zargen 6026/350	350 (13 3/4")	17767-04	10
Zargen 6026/400	400 (15 3/4")	17768-04	10
Zargen 6026/440	440 (17 3/8")	11103-04	10
Zargen 6026/470	470 (18 1/2")	11128-04	10
Zargen 6026/510	510 (20 1/16")	17771-04	10
Zargen 6026/550	550 (21 5/8")	17772-04	10
Zargen 6026/400	400 (15 3/4")	17768-16	400
Zargen 6026/440	440 (17 3/8")	11103-16	400
Zargen 6026/470	470 (18 1/2")	11128-16	400
Zargen 6026/510	510 (20 1/16")	17771-16	400
Zargen 6026/550	550 (21 5/8")	17772-15	300

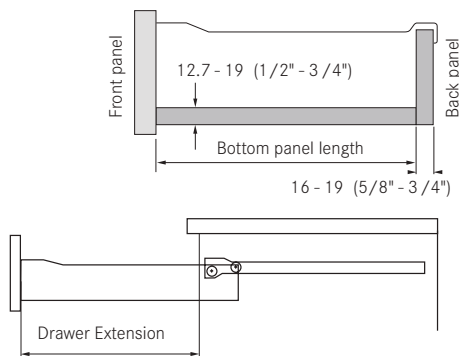

Slide Length	Bottom Panel Length		Extension	
	16mm (5/8") Back Panel	19mm (3/4") Back Panel	Single Stop	Double Stop
350 (13 3/4")	331 (13 1/16")	328 (12 15/16")	280 (11")	-
400 (15 3/4")	381 (15")	378 (14 7/8")	300 (11 13/16")	314 (12 3/8")
440 (17 3/8")	421 (16 9/16")	418 (16 7/16")	340 (13 3/8")	354 (13 15/16")
470 (18 1/2")	451 (17 3/4")	448 (17 5/8")	370 (14 9/16")	384 (15 1/8")
510 (20 1/16")	491 (19 5/16")	488 (19 3/16")	410 (16 1/8")	424 (16 11/16")
550 (21 5/8")	531 (20 7/8")	528 (20 13/16")	450 (17 11/16")	464 (18 1/4")

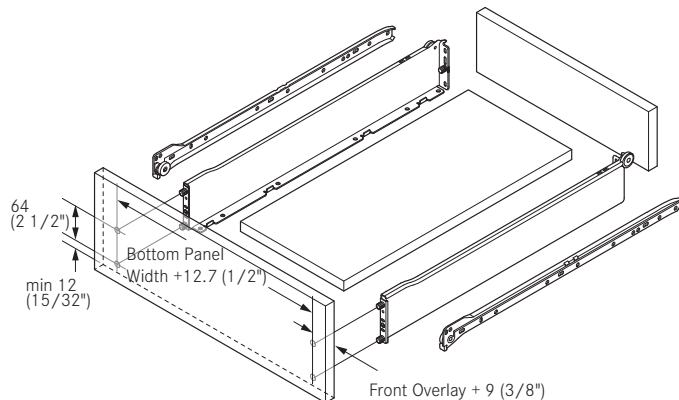

PU - Packaging unit

Drawer Back and Bottom Measurements

Drawer Back and Bottom Measurements with 6100 Railing Installation

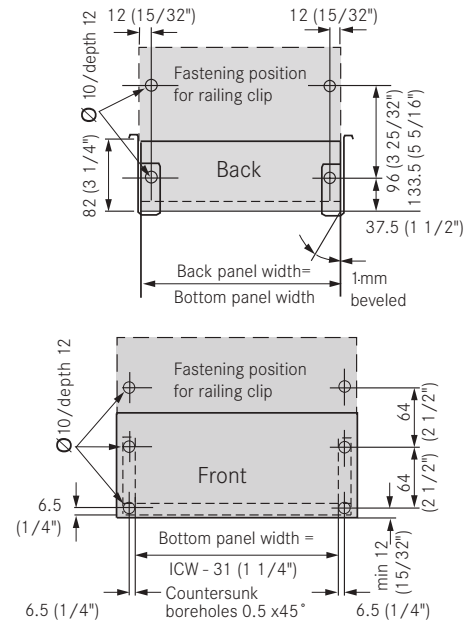
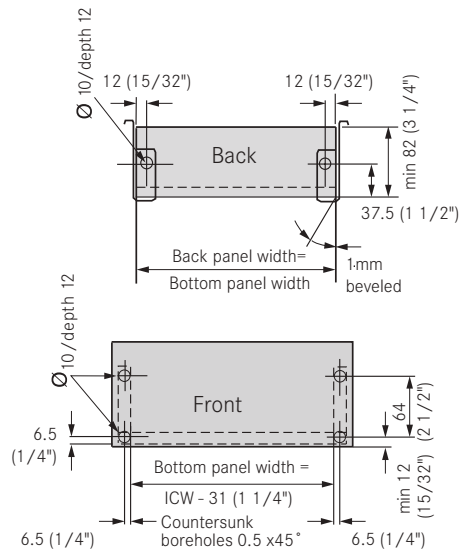

Drawer Installation Measurements

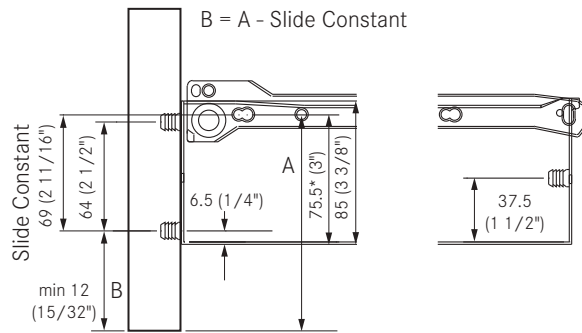
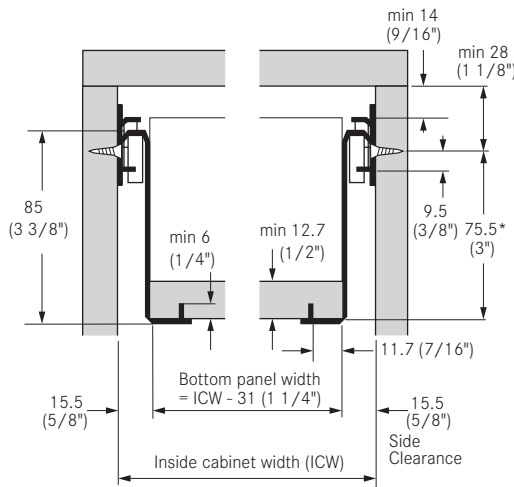

*Allow minimum of 3mm (1/8") for bottom clearance.
If screws are used, increase clearance accordingly.

Drawer slide attachment:

Wood screws #6 x 5/8 FHP

Euro screw lengths 18mm, 13mm, 7.5mm

Bottom panel thickness: 12.7 - 19mm (1/2" - 3/4")

Back panel thickness: 16 - 19mm (5/8" - 3/4")

Back panel height: min 82 (3 1/4")

All dimensions in millimeters.

Zargen 6035

43mm (1 11/16") Side Height



- Integrated drawer slide and drawer side
- Self-closing feature with 60mm (2 3/8") closing range
- Built-in drawer front bumpers
- Quick assembly through dowelled and integrated front fixing brackets
- White epoxy finish
- Tolerance adjustment 2mm (3/32")
- Load capacity: 100 lb
- Adjustments: Cam height (± 2 mm), side (± 1.5 mm)
- Made in the USA

Zargen 6035 slide, 100 lb (45 kg)



Description	Slide Length	Item No.	PU
Zargen 6035/270	270 (10 5/8")	12119-04	10
Zargen 6035/350	350 (13 3/4")	12120-04	10
Zargen 6035/400	400 (15 3/4")	12121-04	10
Zargen 6035/440	440 (17 3/8")	12122-04	10
Zargen 6035/470	470 (18 1/2")	12123-04	10
Zargen 6035/510	510 (20 1/16")	12124-04	10
Zargen 6035/550	550 (21 5/8")	12125-04	10

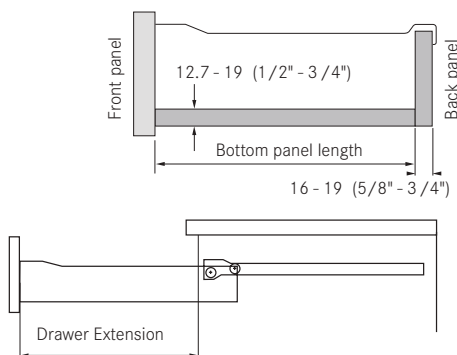

Slide Length	Bottom Panel Length		Extension	
	16mm (5/8") Back Panel	19mm (3/4") Back Panel	Single Stop	Double Stop
350 (13 3/4")	331 (13 1/16")	328 (12 15/16")	280 (11")	-
400 (15 3/4")	381 (15")	378 (14 7/8")	300 (11 13/16")	314 (12 3/8")
440 (17 3/8")	421 (16 9/16")	418 (16 7/16")	340 (13 3/8")	354 (13 15/16")
470 (18 1/2")	451 (17 3/4")	448 (17 5/8")	370 (14 9/16")	384 (15 1/8")
510 (20 1/16")	491 (19 5/16")	488 (19 3/16")	410 (16 1/8")	424 (16 11/16")
550 (21 5/8")	531 (20 7/8")	528 (20 13/16")	450 (17 11/16")	464 (18 1/4")

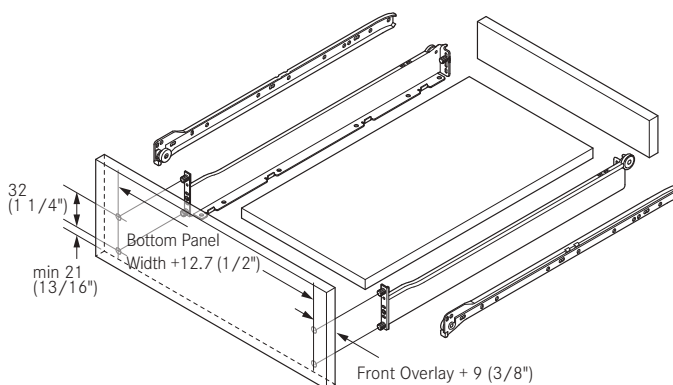

PU - Packaging unit

Zargen Soft-close

Damper set

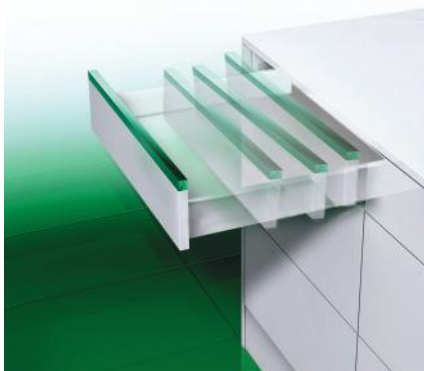

- Add-on damper creates a smooth soft-close action for Zargen drawers
- Liquid closing mechanism for improved performance
- Three options for various load capacities
- Height adjustment $\pm 2\text{mm}$ via elongated hole
- Secure striker plate engagement
- Actuator design allows for flush mounting
- Set includes: damper and actuator unit

Soft-close Damper



Description	Load Capacity	Item No.	PU
15 kg Damper set	33 lb	02564-11	140
30 kg Damper set	66 lb	02572-11	140
70 kg Damper set	154 lb	02565-11	140

Note: Damper sets do not include screws.

Soft-close Damper Placement



Dampers per drawer

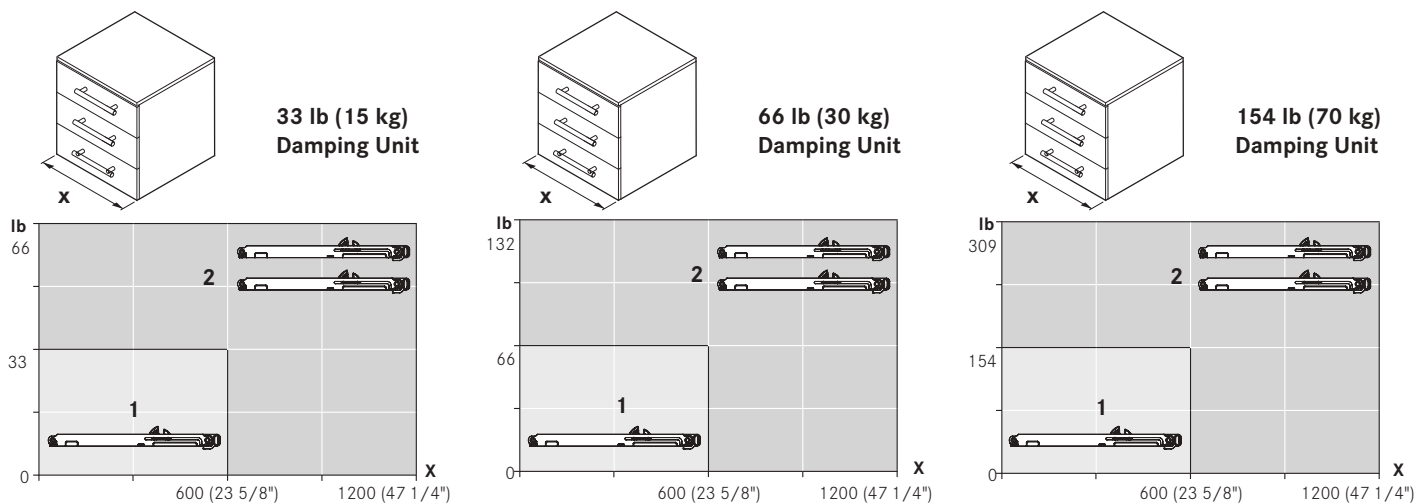

PU - Packaging unit

Product specifications

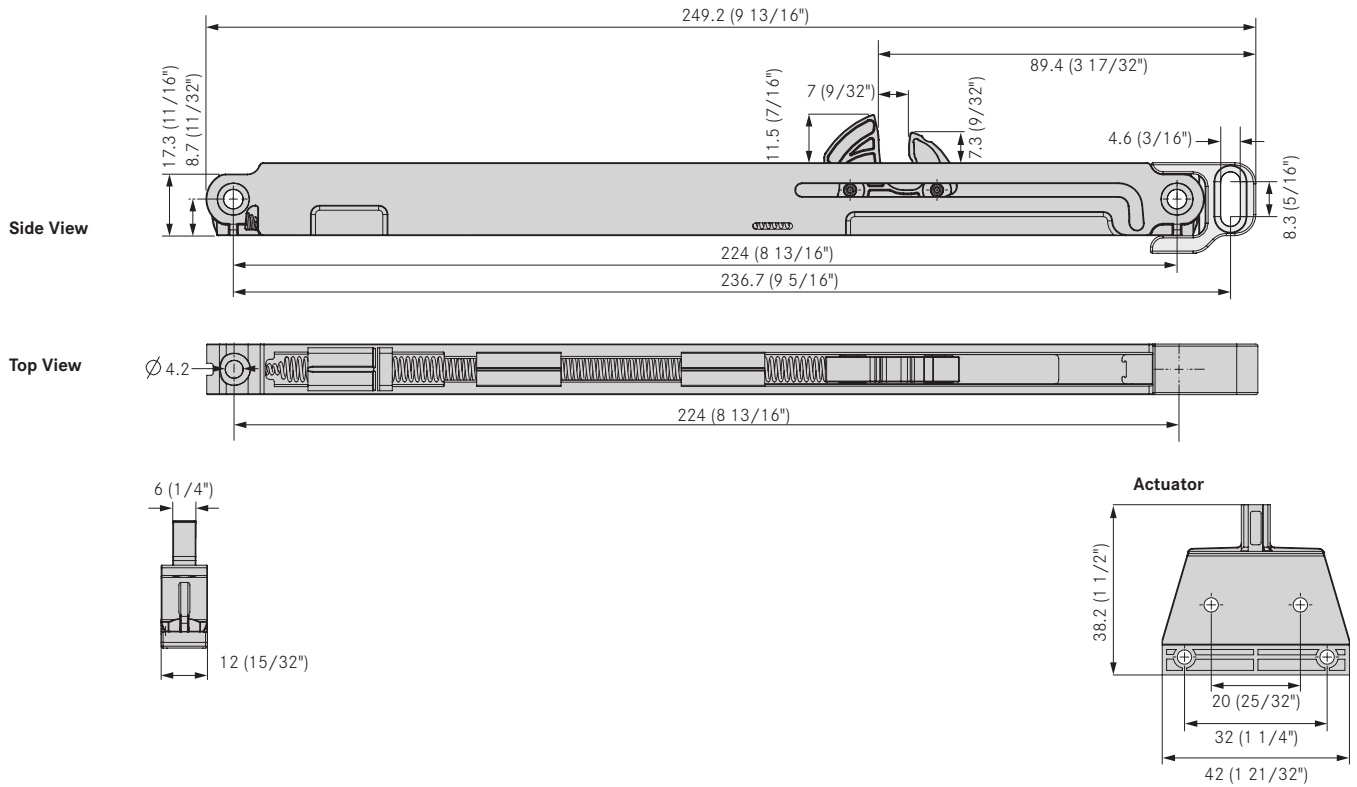

Mounting dimensions

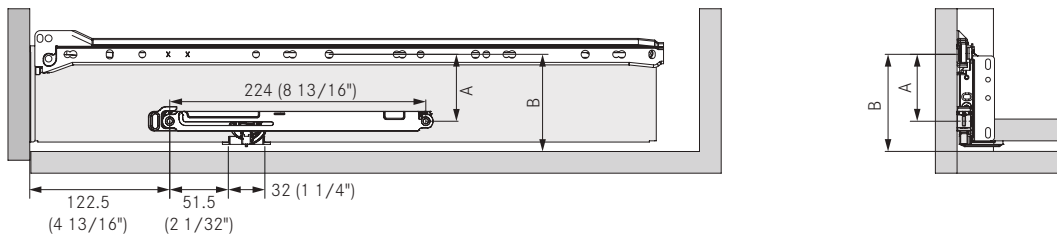

Zargen	A	B
43	16.5	43
85	58.5	85
117	90.5	117
149	122.5	149
213	186.5	213

Recommended screws are:

#4 x 1/2" Phillips flat head wood screws

#4 x 3/4" Phillips pan head wood screws

6100 Railing System

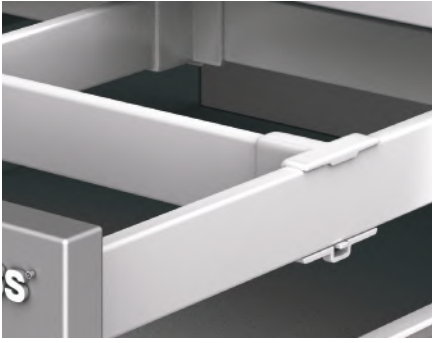

- Designed for use with ZBox and Zargen Systems
- Easy to construct
- Allows end user to customize storage space
- Includes convenient rail dividers
- Available in white

6100 Railing System

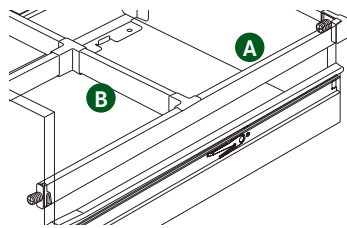

Front railing clip
Dowelled

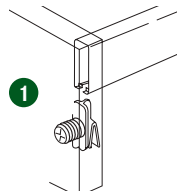

Front partition clip
Screw-on

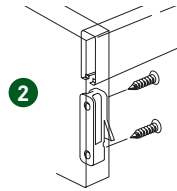

Back railing clip
Dowelled

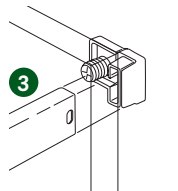

Back railing clip
Screw-on

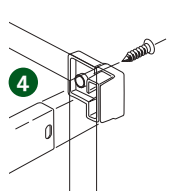

Back partition clip
Screw-on

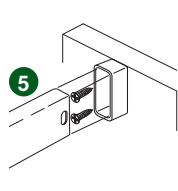

Divider railing clip

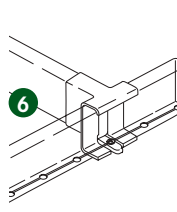

Corner Bracket

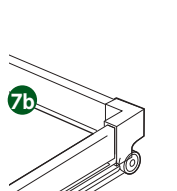
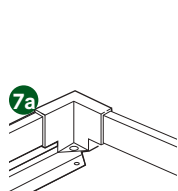

Description	Slide Length	Item No.	PU
A 6100-02 Side Railing 345 (13 9/16")	350 (13 3/4")	F085098128 211	20
6100-02 Side Railing 395 (15 9/16")	400 (15 3/4")	F085096773 211	20
6100-02 Side Railing 435 (17 1/8")	440 (17 3/8")	F085096774 211	20
6100-02 Side Railing 465 (18 5/16")	470 (18 1/2")	F085096775 211	20
6100-02 Side Railing 505 (20")	510 (20 1/16")	F085096776 211	20
6100-02 Side Railing 545 (21 3/8")	550 (21 5/8")	F085097210 211	20
B 6100-02 Divider Railing - cut to size	Railing length 1000 (39 3/8")	F085096783 211	20

Description	Item No.	PU
1 6150-01 Front railing clip, dowelled	F145096360 111	20
2 6150-HF Front partition clip, 4.2mm screw-on	F145098829 111	20
3 6150-02 Back railing clip, dowelled	F145096719 123	100
4 6150-03 Back railing clip, 4.2mm screw-on	F145096769 111	20
5 6150-20 Back partition clip, 4.2mm screw-on	F145097480 111	20
6 6180-01 Divider railing clip	F145096770 111	20
7a 6190-01 Corner bracket, LH	F145096771 111	20
7b 6190-01 Corner bracket, RH	F145096772 111	20

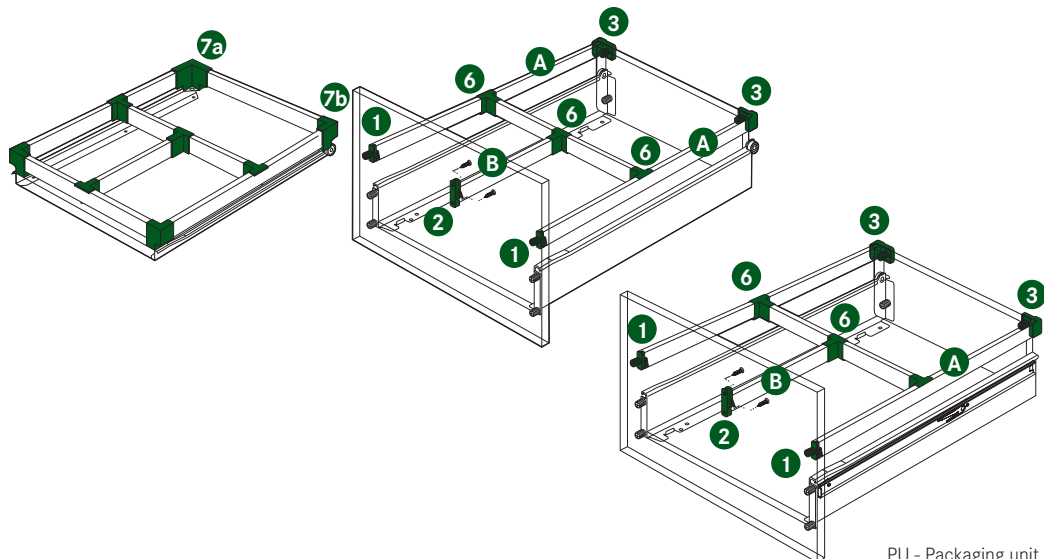

PU - Packaging unit

Pendaflex

6110 File Railing



- The Pendaflex Rail 6110 provides a lip for drop in file folders. It is cut to a desired length and attached over the 6100 side railing.
- Use in conjunction with ZBox and Zargen
- Easy to construct
- White plastic

File Rail 6110

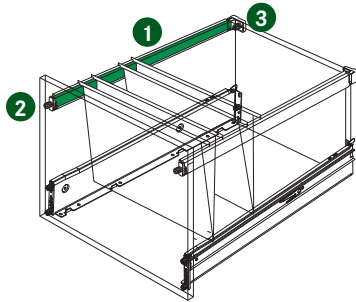

Description	Length	Item No.	PU
1 Pendaflex Rail 6110	1100 (43 5/16")	F145099062211	20
2 Front railing clip, doweled, white		F145096360111	100
3 Back railing clip, doweled, white		F145096719123	100

Drawer Measurements

Inside Cabinet Width

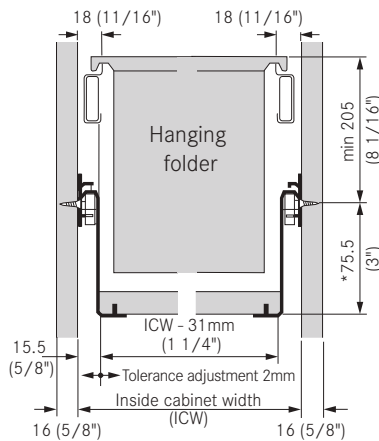

*6036 measurement used.
For other drawer heights,
refer to the appropriate page.

ICW = Inside Cabinet Width
Legal Size paper:
ICW= 418mm (16 7/16")
Letter size Paper:
ICW = 342mm (13 7/16")

Drilling Patterns for Pendaflex File Drawers

Front panel
(manual and automatic assembly)

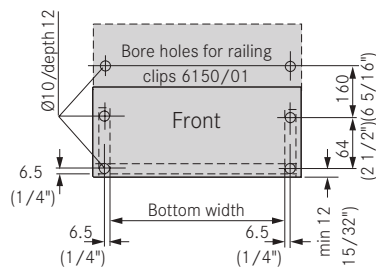

Back panel
(automatic assembly)

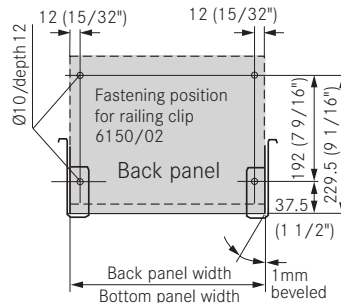

Back panel
(manual assembly)

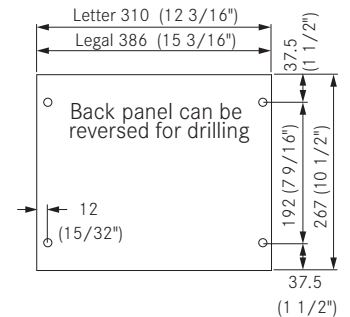

Pendaflex

File Railing



- Designed for use with metal drawer system or wood drawer application
- File bar accommodates lateral file application
- Easy to construct
- Available in white finish

US File Rail

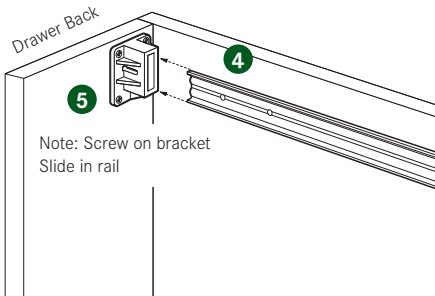
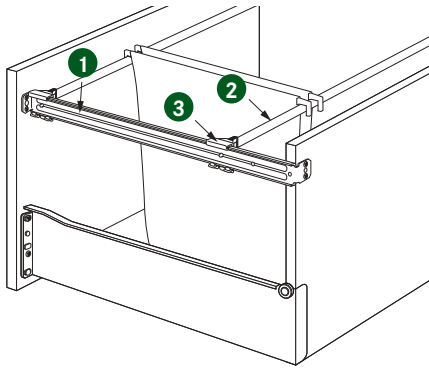

Description	Use With Slide Length	Item No.	PU
1 US/468.5 Side Rail	470 (18 1/2")	01692-05	20
US/508.5 Side Rail	510 (20 1/16")	01690-05	20
US/548.5 Side Rail	550 (21 5/8")	01686-05	20
2 711 (28") File Bar		30890-05	20
3 Lateral File Clip		30954-39	20
4 US/442.5 Partition Rail	470 (18 1/2")	01693-05	20
US/482.5 Partition Rail	510 (20 1/16")	01691-05	20
US/522.5 Partition Rail	550 (21 5/8")	01687-05	20
5 Partition Bracket		30956-39	20

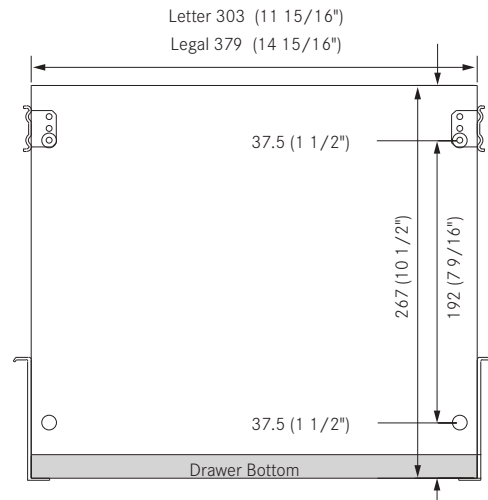

PU - Packaging unit

3595 Pendaflex Aluminum File Railing

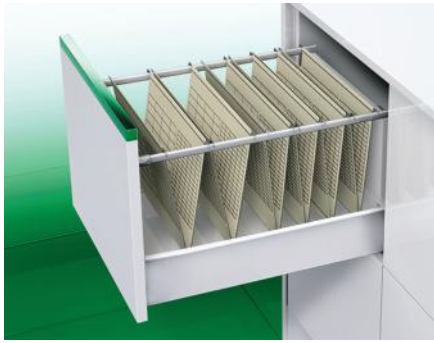

- For Zargen and ZBox drawer systems
- Install file railing system independent from drawer system
- Front tilt adjustment
- Oval aluminum anodized

3595 File Rail

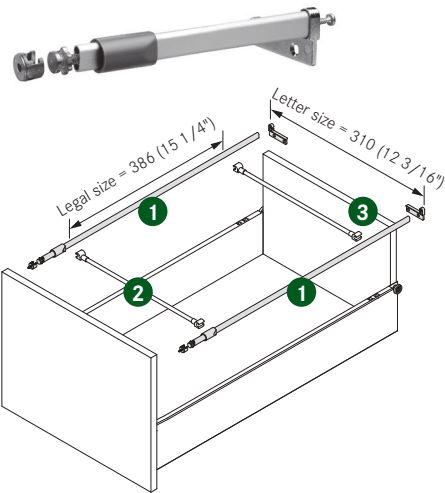

Description	Length	Item No.	PU
1 File Railing Set	500 (20")	F084074850511	20
File Railing Set	550 (22")	F084074851511	20
2 Divider Rail - cut to size	1200 (47 1/4")	F084074854223	20
3 Divider Clips		F084074857133	20

File Railing set consists of:

- 2 Side gallery rails
- 2 Front fixing parts
- 2 Back fixing parts
- 2 Cover caps

Front Tilt Adjustment

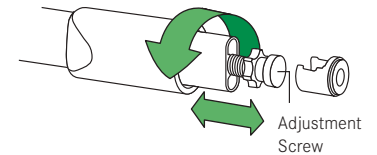

ZBox Installation Instructions

Zargen Installation Instructions

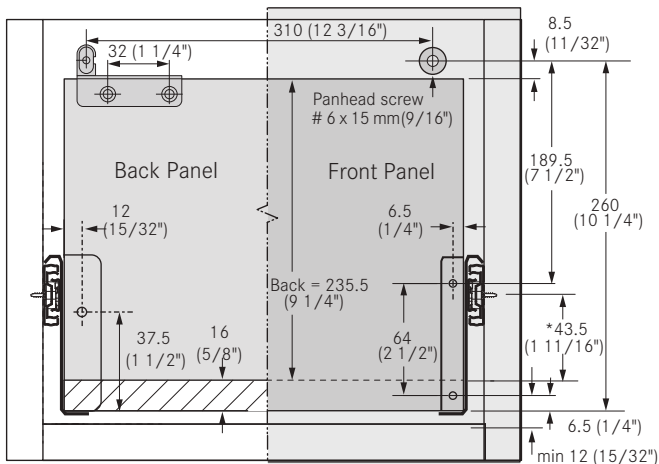

*6023 measurement used. For other drawer heights, refer to the appropriate page.

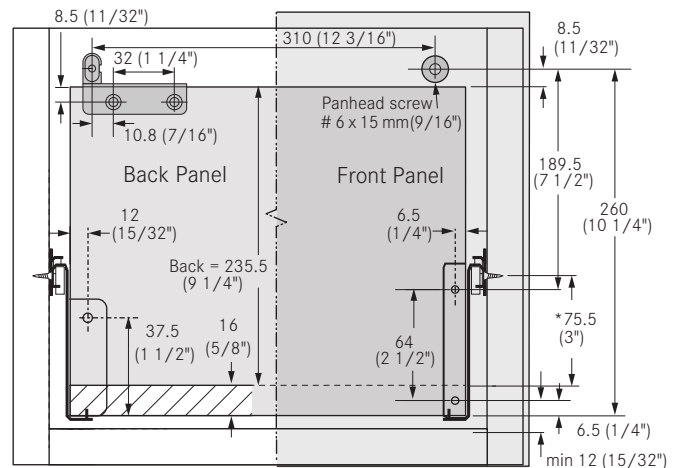

*6036 measurement used. For other drawer heights, refer to the appropriate page.

Accessories and Assembly Aids

ZBox and Zargen

Pilaster Mounting Bracket

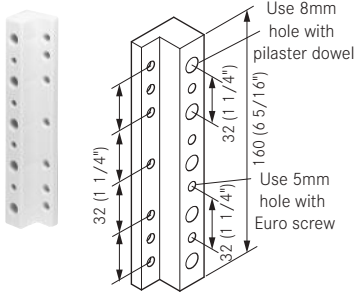

- Fits over 32mm line boring patterns
- Attaches to cabinet with Euro or wood screws
- Allows use of pilaster dowel on cabinet member for an adjustable roll out shelf.
- Allows roll out shelves to be adjustable in 32mm increments

Description	Item No.	PU
Pilaster Mounting Bracket	30912-12	200

Pilaster Dowels



- Allows for construction of adjustable pull-outs with any Zargen Drawer Slide System when attached to cabinet member
- Dowel requires an 8mm x 5/8" deep hole
- Attaches with a #6 x 5/8" or #6 x 1/2" FHP screw

Description	Item No.	PU
Pilaster Dowel, black	00395-43	500

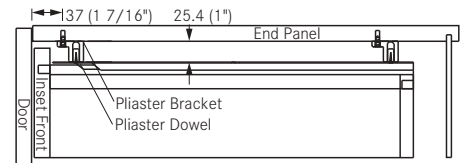

Example shown using 6036 slide with 19mm (3/4") front material

Door/Drawer Protector

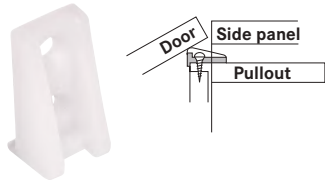

- Attaches to side of wooden pull-out.
- Designed for inset pull-out trays for frame or frameless cabinetry.

Description	Item No.	PU
Door/drawer protector	13096-43	500

6036 Support Bracket



- Attaches to the center of wide drawers for support.
- Elongated holes for drawer front adjustments.

Description	Item No.	PU
6036 Support bracket, nickel	22226-42	100

Central Locking Device



- Use with most commercial gang lock system.
- Provides necessary match for gang lock pins to engage.
- For 6023, 6036, and 6026

Description	Item No.	PU
Central locking device	F145088123238	300

PU - Packaging unit

ZBox and Zargen

6036 Spacer for Inset Drawers

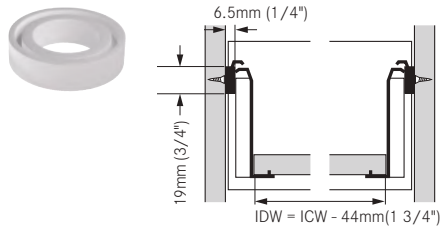

Description	Item No.	PU
6036 Spacer	00035-42	100

6195 Spacers for Cabinet Members



Designed for doors protruding into the cabinet and for inset drawers.

Description	Item No.	PU
1 6195 Spacer, 25mm	F145086478 111	20
2 6195 Spacer, 11mm	89104-39	20
3 6195 Spacer/pin, 25mm	13097-39	20

Screws

Euro Screw, Nickel-plated



Description	Item No.	PU
Euro Screw 11mm (7/16") Pozi	499.360.61.1015	500
Euro Screw 13mm (1/2") Pozi	499.360.61.3015	500

Wood Screw, Nickel-plated



Description	Item No.	PU
#6 x 5/8" FHP, NI	81001-43	500
#6 x 3/4" FHP, NI	81003-43	500

Accessories and Assembly Aids

Zargen

Zargen Front Bracket



- Position bracket on the inside edge of the face frame with the tab resting on the cross rail.
- Brackets can be stapled or screwed.

Description	Item No.	PU
Zargen front bracket	00228-09	100

Roll-out Tray Bracket

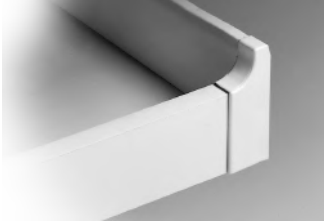

- Allows 6036/6026 slide to be used as roll out tray
- Tray front is 59mm (2 5/16")
- Bracket mounts to front of slide
- Color: white

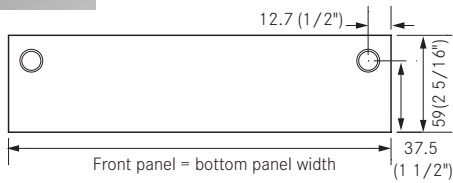

Description	Item No.	PU
6036/6026 Roll out tray bracket - Polybag	30570-05	20
6036/6026 Roll out tray bracket set	30561-15	300
#4 X 3/8", NI screws	00073-43	500

Polybag consists of:

- 2 - Brackets, LH and RH
- 2 - Clamps
- 4 - #4 X 3/8", NI screws

Set consists of:

- 2 - Brackets, LH and RH
- 2 - Clamps

Roll-out Tray Bracket, Dowelled



- Allows 6036/6026 slide to be used as roll out tray
- Tray front is 76.2mm (3")
- For use with 5/8" (16mm) drawer front material
- Bracket mounts to the front of slide
- No need to remove the adjustment bracket
- Color: white

Description	Item No.	PU
6036/6026 Roll out tray bracket - Dowelled	30573-15	300

Set consists of:

- 2 - Brackets, LH and RH

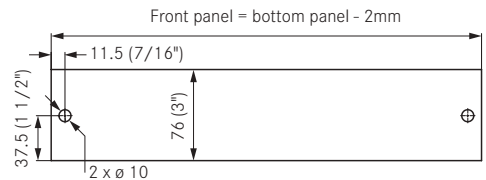
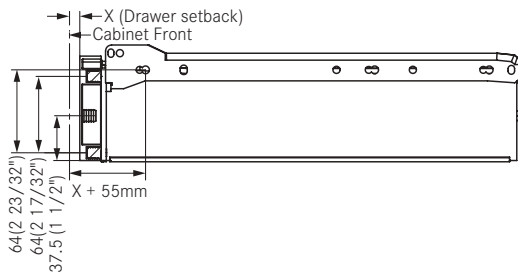

PU - Packaging unit

Accessories and Assembly Aids

ZBox & Zargen Mounting Brackets

Zargen

6196 Bracket



- Attaches cabinet member of drawer slide if no side panel is available
- Bracket can be used for right or left
- Polybag includes 4 brackets with screws

Description	Item No.	PU
6196 Bracket	00432-08	50

Polybag set consists of:

- 4 - Brackets
- 8 - Screws #10 x 5/8" PHP Screws

6035

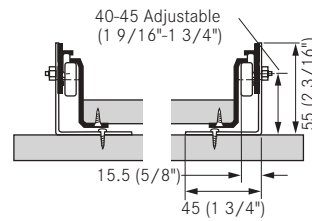

6036

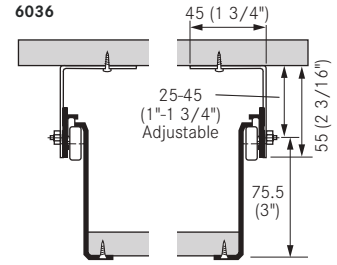

Rear Mounting Socket



- Drawer slide can slide in or out to achieve different cabinet depth
- Extra long length
- Socket can be stapled or screwed

Description	Item No.	PU
Rear mounting socket, left	13946-09	100
Rear mounting socket, right	13947-09	100
Rear mounting socket, left	13946-17	500
Rear mounting socket, right	13947-17	500

ZBox

Inset Bracket Set



For ZBox face frame application, the inset bracket provides a simple solution to attach the cabinet member to the face frame without having to block out the cabinet.

- Bracket mounts behind the face frame, minimum 12.7mm (1/2") frame required
- Includes guide markings for proper setback of 37mm



Description	Item No.	PU
Inset bracket set	13901-37	1
Inset bracket set	13901-08	50

Polybag set consists of:

- 2 - Universal Inset Bracket ABS Brown
- 2 - 8 X 32 Tapped Insert for Inset bracket
- 4 - #7 X 2" mounting screws
- 2 - #8 - 32 X 1/2" Machine Screw FHP
- 1 - Instructions

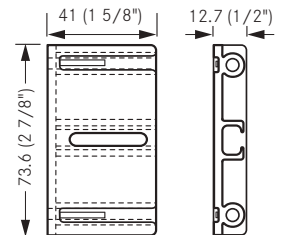

Face Frame Brackets

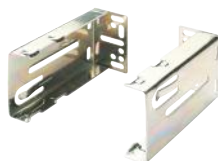

Description	Item No.	PU
Face frame rear mount bracket	30200-09	100

Machinery

Grass PRO1 and ZRam for ZBox and Zargen Assembly

Grass PRO1 for ZBox and Zargen



- Depth stop can be adjusted to material thickness
- Functional design
- Easy, fast and efficient operation
- Easy maintenance
- 3 spindle gear box

Description	Item No.	PU
220v single phase pneumatic	80131	1
220v three phase pneumatic	80132	1
110v single phase pneumatic	80068	1



Description	Item No.	PU
Extension fence 300mm to 1250mm	88612-01	1

ZBox and Zargen Conversion Kit

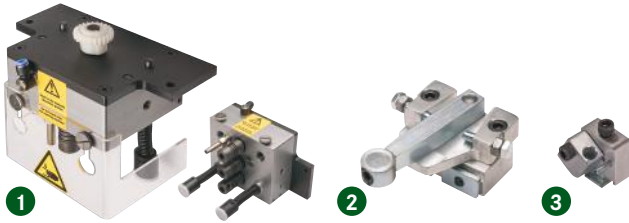

Description	Item No.	PU
1 PRO1 Gear box	80151	1
2 PRO1 Side-to-side Stop	80153	1
3 PRO1 13mm Fence Stop	80152	1
4 PRO1 Kit (gear box, fence and side stops)	80154	1

Bits

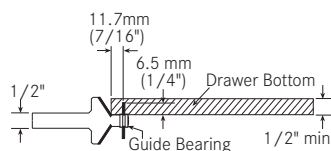
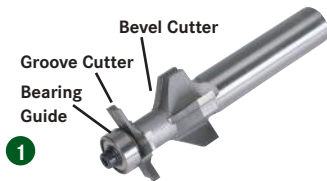

This bit is designed for grooving and beveling the drawer bottoms for the lipped version of the ZBox and Zargen drawer slide. The bit comes only with a 1/2" shank.



Two 00222-01 bits are needed for the Zargen and ZBox Grass PRO1 setup.

Description	Item No.	PU
1 Router bit	00197-01	1
Description	Item No.	PU
2 10mm Carbide counter sink drill bit, LH	00222-01	1

ZRam



- Designed for semi-automated assembly of ZBox and Zargen slides
- Operated by a foot pedal – air required
- No adjustment required when using various heights or when switching slide types
- Economical solution for drawer assembly

Description	Item No.	PU
ZRam	93250-01	1
ZRam Retrofit Kit	69401	1

PU - Packaging unit

Assembly of ZBox and Zargen

Grass PRO 1

To assemble, drill drawer back dowel holes for each side by positioning back against the side-to-side stop.

To ensure correct positioning of the drawer front dowel holes, place drilled drawer back against right side of 13mm stop. Set floating side stop at opposite end of panel. Drill bits are countersunk to allow for easy installation of dowels.

To drill right side of drawer front, place front against the 13mm stop. To drill left side, place front against floating side stop.



ZRam

To insert the slide, position the slide against the ZRam arm and place drawer back over the dowel. Repeat for other side.

Place drawer front face down on ZRam. Position slide over dowel holes and depress foot pedal. Repeat for other side.

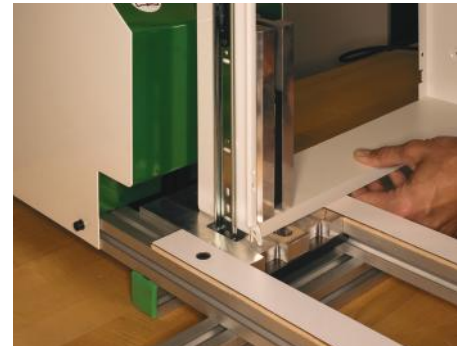

After assembly is complete, place drawer box on a stable surface and press bottom firmly over tabs.

Note: The same process is used for the assembly of both the ZBox and Zargen drawer systems.





GRASS America Inc.
1202 NC Highway 66 South
Kernersville, NC 27284

Phone: 1-800-334-3512
Fax: 1-800-525-8406

www.grassusa.com
info@grassusa.com

GRASS Canada Inc.
10 Newgale Gate, Unit 7
Toronto, ON M1X 1C5

Phone: 1-800-461-4975
Fax: 1-416-335-5907

www.grasscanada.com
info@grasscanada.com

